



# Monnit Wi-Fi Infrared Motion Sensor

## Technical Overview



### General Description

The Monnit Wi-Fi Infrared Motion Sensor uses an infrared sensor to accurately detect movements made by people or large animals within 16.4 ft (5 m) range. An integrated 802.11 b/g radio allows the sensor to work with any existing Wi-Fi network. Monnit Wi-Fi sensors can be easily programmed with your Wi-Fi network's WEP or WPA(2) security via the free MoWi Setup Utility (PC application) and a MoWi USB programming cable (available in the [Monnit web store](#)).

### Features

- Passive Infrared Technology.
- Sensing Range of 16.4 ft (5 m).
- Logs data if Wi-Fi network is disrupted.
- Free iMonnit basic online wireless sensor monitoring and notification system to configure sensors, view data and set alerts via SMS text and email.

### Principle of Operation

The Monnit Wi-Fi Infrared Motion Sensor detects motion and movement using infrared technology. When the sensor detects movement it communicates with the iMonnit Online Sensor Monitoring and Notification System. iMonnit stores all data in the online system where the data can be reviewed and exported as a data sheet or graph. Notifications can be set up through the online system to alert the user when motion has been detected.

### High Gain Antenna Option

Monnit Wi-Fi sensors are also available with a detachable high gain antenna to provide a 20-30% increase in range over the standard Wi-Fi sensor. Option uses a different hardware configuration and must be chosen at time of purchase.



### Monnit Wi-Fi Sensor Electronics Specifications

- Power: 2 replaceable 1.5V "AA" batteries (included)
- Communication: 802.11 b/g  
(2.412 - 2.484 GHz)
- Wi-Fi Security: Open, WEP, WPA, WPA2
- Dimensions: 3.02" x 2.1" x 1.27"
- Transmission Range: Up to 100 ft. \*
- Battery Life: Up to 1 year.\*\*

\* Actual range may vary depending on environment.  
\*\* Battery life is affected by sensor usage, Wi-Fi security type, distance from Wi-Fi router, reporting frequency and other variables.

Height: 1.270 in (32.258 mm)

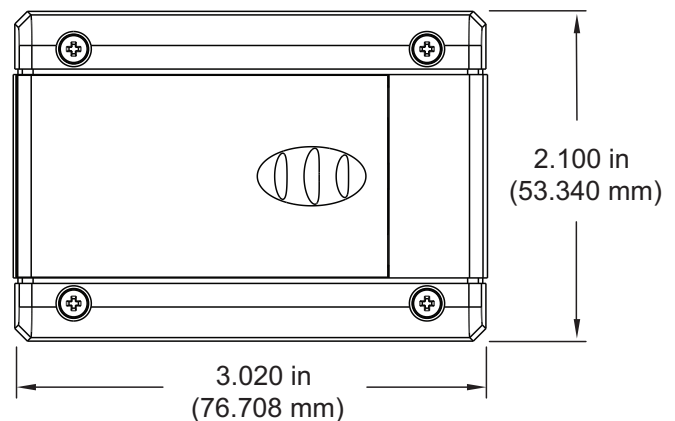

### Applications

- Monitor area access.
- Detect when people enter a room.

**The Leader in Low Cost Wireless Sensors**

## Technical Specifications

Networking Standards	IEEE 802.11 b/g
Frequency Band	2.412 - 2.484 GHz
Wi-Fi Security Standards	Open, WEP, WPA, WPA2
Wi-Fi Security Programming	Via PC software using USB cable. (Can be changed through iMonnit online software.)
Network Settings	Auto DHCP/DNS or Static
Data Logging	Standard - On Wi-Fi disruption, unit will log the first 50 readings and transmit when Wi-Fi connection is re-established. Premiere - Unit can record up to 50,000 readings and transmit when Wi-Fi is available.
Power consumption	4uA sleep, 35mA active RX, 180mA TX (at +12dBm)
Battery Life	Up to 5 years depending on sensor type, Wi-Fi security, distance from Wi-Fi router, reporting frequency and other variables. (Testing surpassed 90,000 transmissions until battery depletion.)
Wi-Fi Data Rate	Auto configures to best rate for maximum range.
Wireless Range	Up to 100 ft. device range (typical to standard Wi-Fi devices).
Electronics Operating Temperature	Using Alkaline Batteries: -18°C to +55°C (0°F to +130°F) Using Lithium Batteries: -40°C to +85°C (-40°F to +185°F)
LED Light	Status / activity
Sensor Warmup Time	30 Seconds
Sensing Technology	Passive Infrared
Sensing Range	16.4 ft (5 m)
Certifications	 FCC ID: T9J-RN171. IC: RSS-210 low-power communication device. CE ID: 0681.

- \* Hardware cannot withstand negative voltage. Please take care when connecting a power device.
- \*\* At temperatures above 100°C, it is possible for the board circuitry to lose programmed memory.

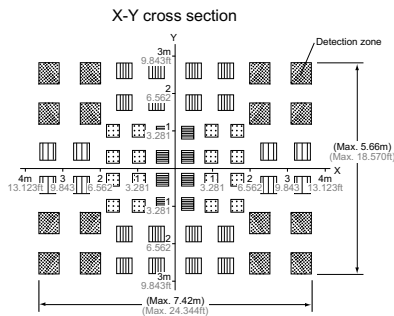
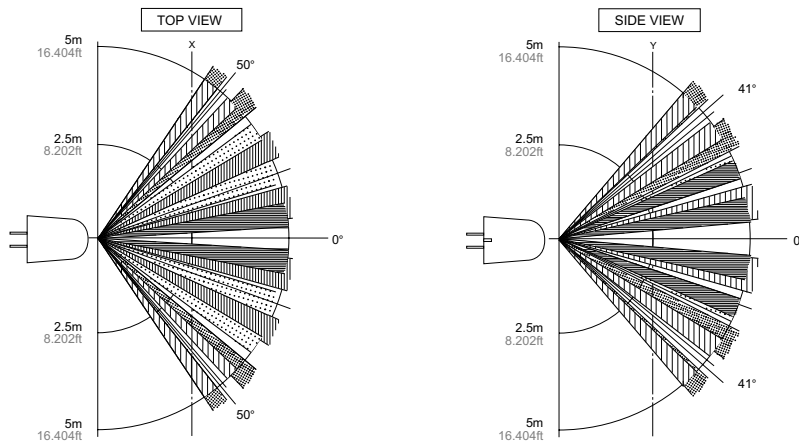

### Remarks:

1. The X-Y cross-sectional diagram shows the detection area.
2. The differences in the detection zone patterns are indicative of the projections of the 16 lenses with single focal point and with five optical axes. An object whose temperature differs from the background temperature and which crosses inside the detection zone will be detected.

**MONNIT**®