



Monnit Wi-Fi Asset Sensor

Technical Overview



General Description

The Monnit Wi-Fi Asset Sensor can be attached to an asset and alert you if the asset is removed from range of the wireless sensor gateway. Monnit Wi-Fi sensors can be easily programmed with your Wi-Fi network's WEP or WPA(2) security via the free MoWi Setup Utility (PC application) and a MoWi USB programming cable (available in the [Monnit web store](#)). User defined transmission intervals (heartbeats) and sensor threshold settings ensure that sensor data is received when needed, based on the application. All sensor data is stored securely in the iMonnit Online Sensor Monitoring software and is viewable from any web enabled device. Email and SMS text messages can be configured through the online system to alert the user immediately when a defined parameter has been met or exceeded.

Features

- Tell if assets leave premises.
- Free iMonnit basic online wireless sensor monitoring and notification system to configure sensors, view data and set alerts via SMS text and email.

Principle of Operation

The Monnit Wi-Fi Asset Sensor outputs an RF signal at set intervals to be received by the Wi-Fi network and monitoring system. The sensor can be used determine if an asset is removed from the premises and send notifications via SMS text or email from the system to alert the user.

High Gain Antenna Option

Monnit Wi-Fi sensors are also available with a detachable high gain antenna to provide a 20-30% increase in range over the standard Wi-Fi sensor. Option uses a different hardware configuration and must be chosen at time of purchase.



Monnit Wi-Fi Sensor Electronics Specifications

- Power: 2 replaceable 1.5V "AA" batteries (included)
- Communication: 802.11 b/g
(2.412 - 2.484 GHz)
- Wi-Fi Security: Open, WEP, WPA, WPA2
- Dimensions: 3.02" x 2.1" x 1.27"
- Transmission Range: Up to 100 ft. *
- Battery Life: Up to 5 years.**

* Actual range may vary depending on environment.
** Battery life is affected by sensor type, Wi-Fi security type, distance from Wi-Fi router, reporting frequency and other variables.

Height: 1.270 in (32.258 mm)

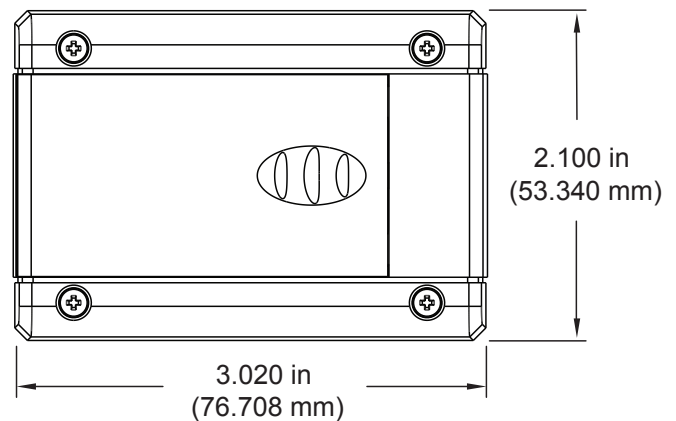

Applications

- Asset monitoring.
- Tell if school buses are on premises.
- Tell if fleet vehicles are on premises.
- Monitor rental tools.
- Construction asset monitoring.

The Leader in Low Cost Wireless Sensors

| Technical Specifications | |
|-----------------------------------|---|
| Networking Standards | IEEE 802.11 b/g |
| Frequency Band | 2.412 - 2.484 GHz |
| Wi-Fi Security Standards | Open, WEP, WPA, WPA2 |
| Wi-Fi Security Programming | Via PC software using USB cable. (Can be changed through iMonnit online software.) |
| Network Settings | Auto DHCP/DNS or Static |
| Data Logging | Standard - On Wi-Fi disruption, unit will log the first 50 readings and transmit when Wi-Fi connection is re-established. Premiere - Unit can record up to 50,000 readings and transmit when Wi-Fi is available. |
| Power consumption | 4uA sleep, 35mA active RX, 180mA TX (at +12dBm) |
| Battery Life | Up to 5 years depending on sensor type, Wi-Fi security, distance from Wi-Fi router, reporting frequency and other variables. (Testing surpassed 90,000 transmissions until battery depletion.) |
| Wi-Fi Data Rate | Auto configures to best rate for maximum range. |
| Wireless Range | Up to 100 ft. device range (typical to standard Wi-Fi devices). |
| Electronics Operating Temperature | Using Alkaline Batteries: -18°C to +55°C (0°F to +130°F) Using Lithium Batteries: -40°C to +85°C (-40°F to +185°F) |
| LED Light | Status / activity |
| Certifications |  FCC ID: T9J-RN171. IC: RSS-210 low-power communication device. CE ID: 0681. |

* Hardware cannot withstand negative voltage. Please take care when connecting a power device.

** At temperatures above 100°C, it is possible for the board circuitry to lose programmed memory.

Caution/Notice:

This product is designed for application in an ordinary environment (normal room temperature, humidity and atmospheric pressure). Do not use this sensor under the following conditions as they can deteriorate the product characteristics and cause failures and burn-out.

- Corrosive gas or deoxidizing gas - chlorine gas, hydrogen sulfide gas, ammonia gas, sulfuric acid gas, nitric oxides gas, etc.).
- Volatile or flammable gas.
- Dusty conditions.
- Under low or high pressure.
- Wet or excessively humid locations.
- Places with salt water, oils chemical liquids or organic solvents.
- Where there are excessively strong vibrations.
- Other places where similar hazardous conditions exist.

Use this product within the specified temperature range. Higher temperature may cause deterioration of the characteristics or the material quality of this product.

