

## PART M-01 ~ M-23

Diameter

● Shielded    ○ non-Shielded

Switching Distance Sn mm

Housing Material

● With LED    ○ Without LED

Dimensions (unit: mm)

Operating Voltage

Ripple

No Load Current

Max. Load Current

Leakge Current

Surge Current

Min. Load Current

Voltage Drop

Switching Frequency

Response Time

Switching Hysteresis

Repeat Accuracy

Protection Category

Operating Temperature

Temperature Drift

Short Circuit Protection

Overload Trip Point

Time Delay Before Availability

EMC

Shock / Vibration

Material Active Face

DC 3 wire 10-30V NPN N.O.

DC 3 wire 10-30V NPN N.C.

DC 3 wire 10-30V PNP N.O.

DC 3 wire 10-30V PNP N.C.

DC 4 wire 10-30V Changeover PNP (N.O. & N.C.)

DC 4 wire 10-30V Changeover NPN (N.O. & N.C.)

DC 2 wire 10-60V N.O.

DC 2 wire 10-60V N.C.

DC 3 wire 5-36v NPN N.O.

DC 3 wire 5-36v NPN N.C.

DC 3 wire 5-36v PNP N.O.

DC 3 wire 5-36v PNP N.C.

AC 2 wire 20-250V N.O.

AC 2 wire 20-250V N.C.

AC 2 wire 20-250V N.O. or N.C. Changeable

AC/DC 2 wire 20-250V N.O.

AC/DC 2 wire 20-250V N.C.

AC/DC 2 wire 20-250V N.O. or N.C. Changeable

Remark

Cable 2M (PVC)

Weight

Please put each catalog page in the blank. The specification on the left will help your reading.

























### LONG SENSING DISTANCE DC 3-WIRE NPN/PNP TYPE

<b>MPS-10</b>
○
6mm
Polycarbonate
●

<b>MPS-12</b>
○
6mm
Polycarbonate
●

<b>MPS-12</b>
○
6mm
Polycarbonate
●

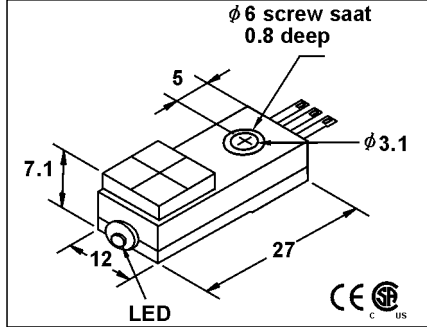
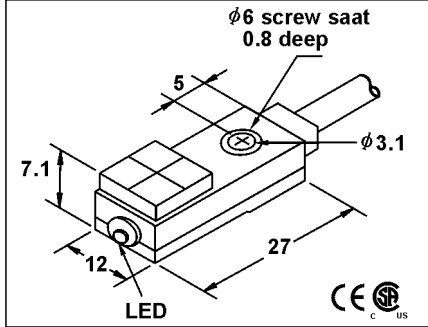
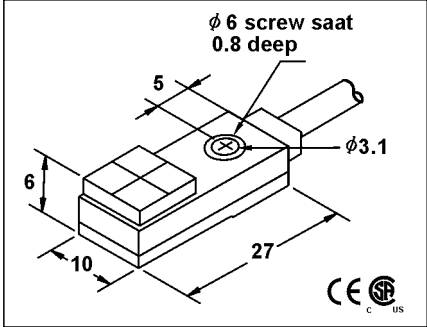

10-30VDC
<10%
<10mA
100mA
<0.01mA
-
<1.5V
250HZ
0.5ms/0.5ms
<15%(Sr)
<0.04mm
IP67
-25 °C - +70 °C
<10%(Sr)
YES
120mA
220mA

10-30VDC	5-36VDC
<10%	<10%
<10mA	<10mA
100mA	200mA
<0.01mA	<0.01mA
-	-
<1.5V(10-30V) or <1.0V(5-36v)	<1.5V(10-30V) or <1.0V(5-36v)
500HZ	500HZ
0.5ms/0.5ms	0.5ms/0.5ms
<15%(Sr)	<15%(Sr)
<0.04mm	<0.04mm
IP67	IP67
-25 °C - +70 °C	-25 °C - +70 °C
<10%(Sr)	<10%(Sr)
YES	YES
120mA	220mA

10-30VDC	5-36VDC
<10%	<10%
<10mA	<10mA
100mA	200mA
<0.01mA	<0.01mA
-	-
<1.5V(10-30V) or <1.0V(5-36v)	<1.5V(10-30V) or <1.0V(5-36v)
500HZ	500HZ
0.5ms/0.5ms	0.5ms/0.5ms
<15%(Sr)	<15%(Sr)
<0.04mm	<0.04mm
IP67	IP67
-25 °C - +70 °C	-25 °C - +70 °C
<10%(Sr)	<10%(Sr)
YES	YES
120mA	220mA

<10ms
RFI>3V/m / EFT>1KV / ESD>4KV (contact)
IEC 60947-5-2, Part 7.4.1 / IEC 60947-5-2, Part 7.4.2
Polycarbonate

<10ms
RFI>3V/m / EFT>1KV / ESD>4KV (contact)
IEC 60947-5-2, Part 7.4.1 / IEC 60947-5-2, Part 7.4.2
Polycarbonate

<10ms
RFI>3V/m / EFT>1KV / ESD>4KV (contact)
IEC 60947-5-2, Part 7.4.1 / IEC 60947-5-2, Part 7.4.2
Polycarbonate

MQP2-1006N-A3U2F	C
MQP2-1006N-B3U2F	C
MQP2-1006P-A3U2F	D
MQP2-1006P-B3U2F	D

MQP2-1206N-A3U2F	C
MQP2-1206N-B3U2F	C
MQP2-1206P-A3U2F	D
MQP2-1206P-B3U2F	D
C	IQP2-1206N-A3U2F
C	IQP2-1206N-B3U2F
D	IQP2-1206P-A3U2F
D	IQP2-1206P-B3U2F

MQP2-1206N-ANU3F	E
MQP2-1206N-BNU3F	E
MQP2-1206P-ANU3F	F
MQP2-1206P-BNU3F	F
E	IQP2-1206N-ANU3F
E	IQP2-1206N-BNU3F
F	IQP2-1206P-ANU3F
F	IQP2-1206P-BNU3F

3 ϕ 3x0.15
approx.20 g

3 ϕ 3x0.15
approx.20 g

MCP2-1202N-ANU3F
3 PIN connector type see page L-10
approx.5 g





# I/O CIRCUIT AND WIRING DIAGRAMS

## (A) DC 2-WIRE

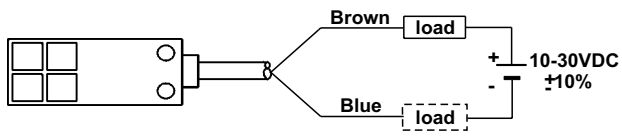

WIRING DIAGRAM

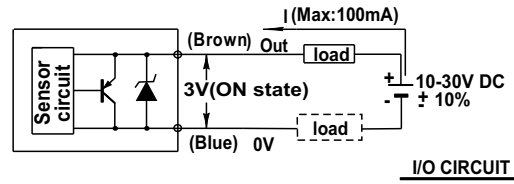

## (B) DC 2-WIRE

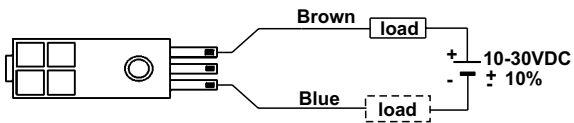

WIRING DIAGRAM

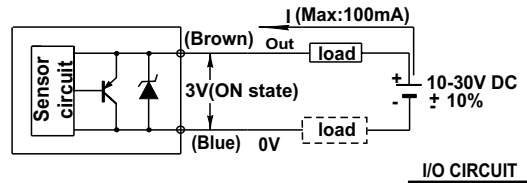

## (C) NPN OUTPUT

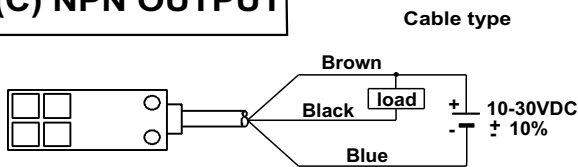

WIRING DIAGRAM

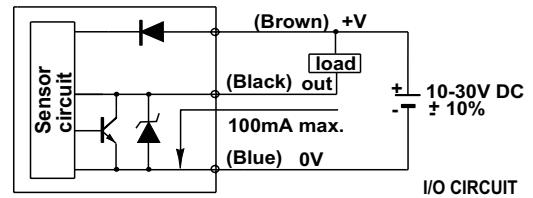

## (D) PNP OUTPUT

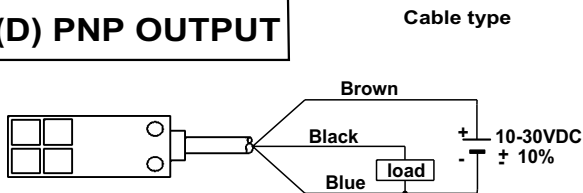

WIRING DIAGRAM

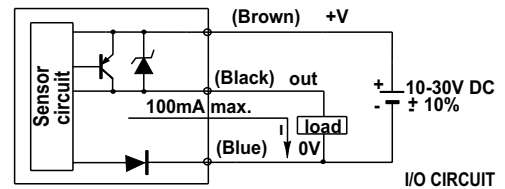

## (E) NPN OUTPUT

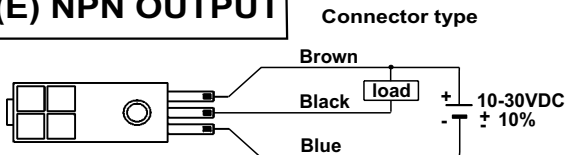

WIRING DIAGRAM

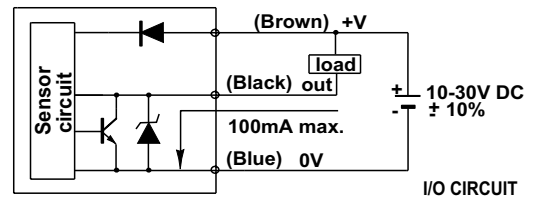

## (F) PNP OUTPUT

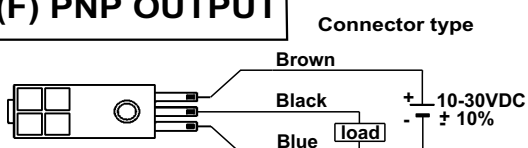

WIRING DIAGRAM

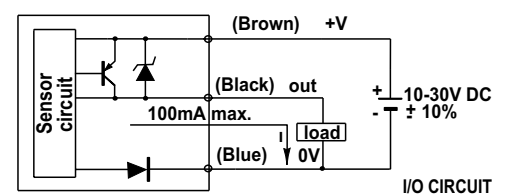



# OPTIONNAL COMPONENTS

	Component	Model name	Description
1	Connector	SN-13	Connect for the terminal type
2		SN-13-C1(C3)	cable for the terminal type C1=1m Length C3=3m Length
3	Sensor mounting bracket	SS-MPS8-3	Mounting bracket for MPS-8 type
4		SS-MPS6-2	Mounting bracket for MPS-6 type
5		SS-MPS15-2	Mounting bracket for MPS-15 type
6		SS-MPS12-2	Mounting bracket for MPS-12 type
7		SS-MPS8-4	Mounting bracket for MPS-8-4 type
8		SS-MPS12-1	Mounting bracket for MPS-12 type
9		SS-MPS15	Mounting bracket for MPS-12

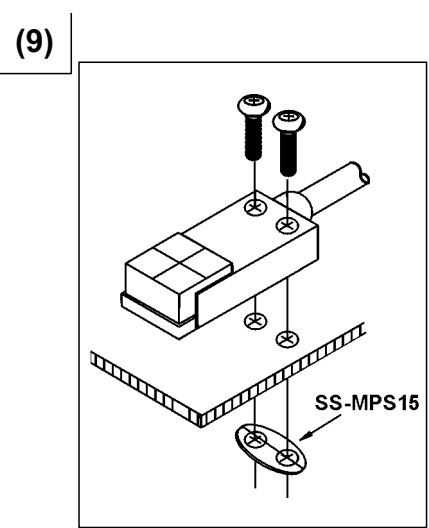
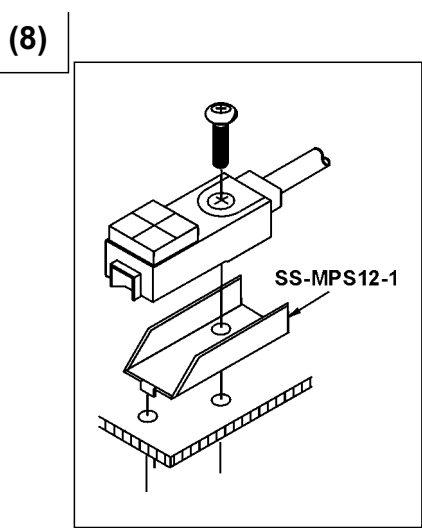
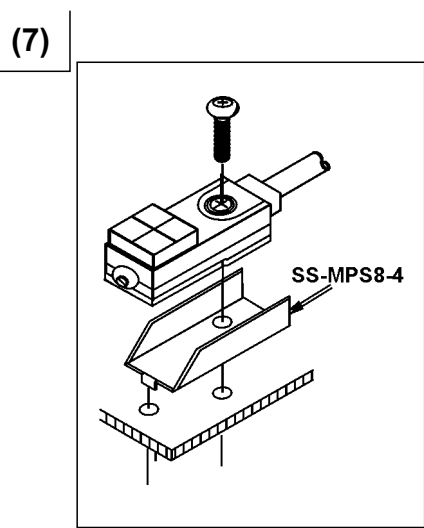
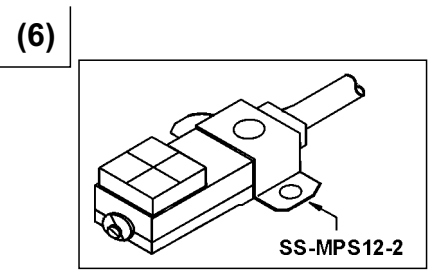
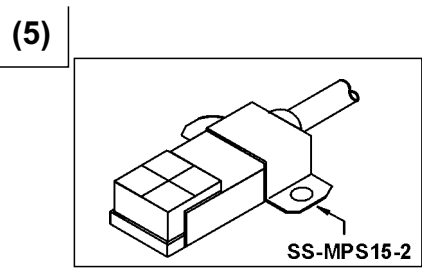
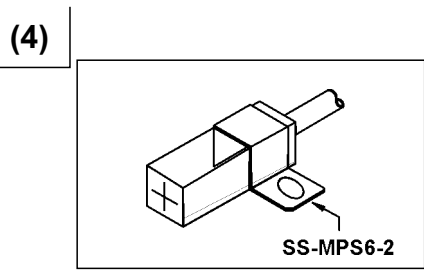
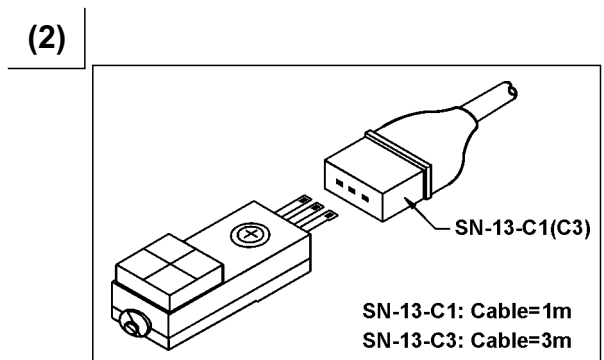
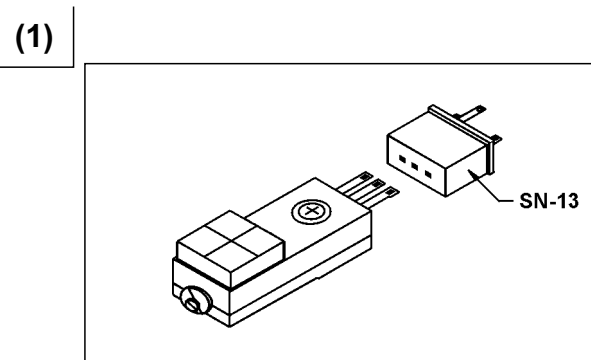
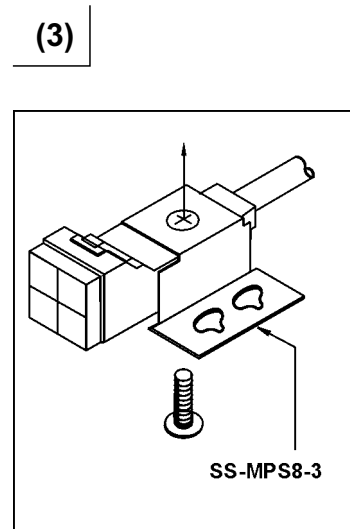

# MOUNTING

## MPS-6 type

.Mount the sensor with the attached mounting bracket SS-MPS-1 or the optional mounting bracket SS-MPS6-2.

.Prepare a screw, a nut, and a washer that you may have, as they are not attached.

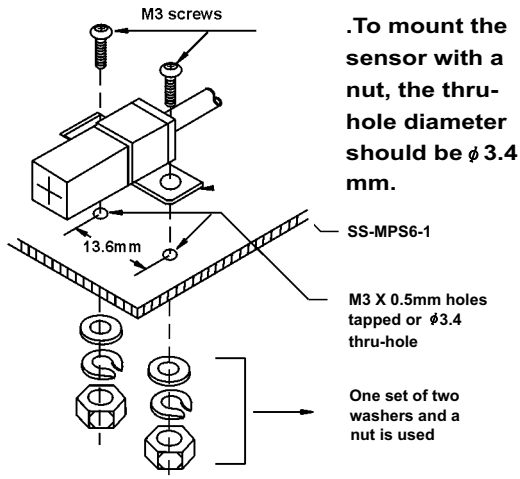

## MPS-8 type

.The tightening torque should be 0.5N.m(5.1kgf.cm) or less.

.To mount the sensor with a nut, the thru-hole diameter should be  $\phi$  3.4mm. with the attached mounting screw and nut, the thickness of a mounting plate should be 2.3mm or less.

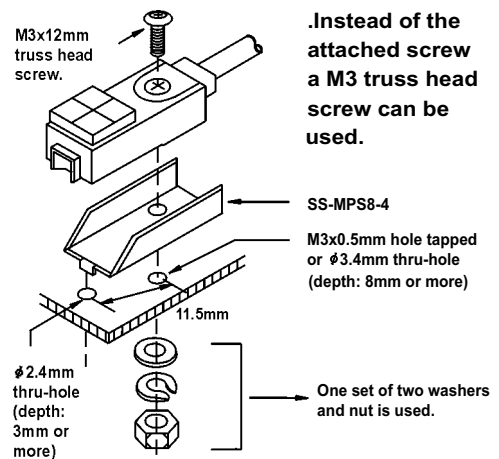

## MPS-12 type

.The tightening torque should be 0.49N-M or less.

.To mount the sensor with a nut, the thru-hole diameter should be  $\phi$  3.4mm.

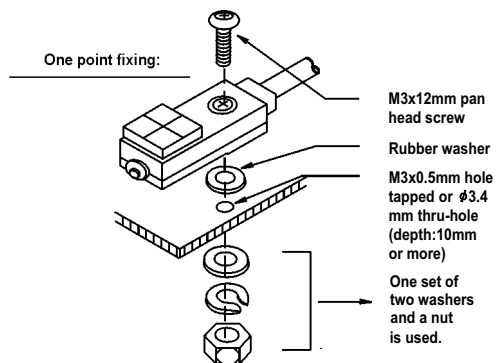
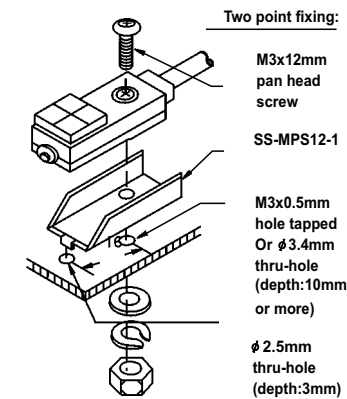

## MPS-15 type

.The tightening torque should be 1N-m(10.2kgf.cm) or less.

.To mount the sensor with the optional mounting bracket SS-MPS15, the thru-hole diameter should be  $\phi$  3.4mm. .No screw, nut, nor washer is supplied.

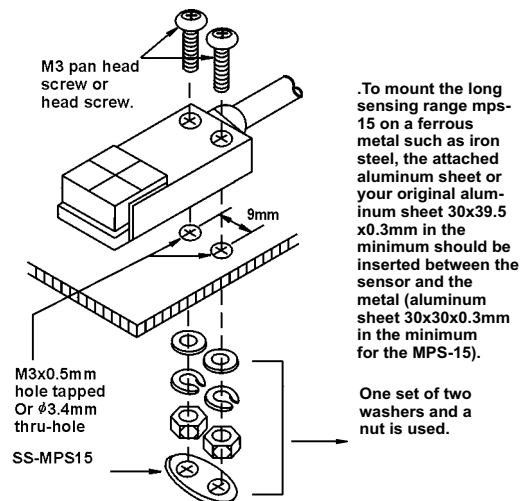

# PRECAUTIONS FOR PROPER USE

## Influence by surrounding metal

.When there are metals near the sensor, keep the separation distance specified below at the minimum

Front sensing:

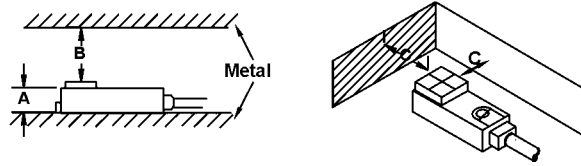

	MPS-6	MPS-8	MPS-12	MPS-15	MPS-15L
A	6mm	7mm	7mm	8mm	8mm *
B	8mm	8mm	20mm	20mm	30mm
C	3mm	3mm	10mm	7mm	10mm

\*: The MPS-15L should be mounted on an insulator or a non-ferrous metal. To mount it on a ferrous metal such as iron steel, use the attached aluminum sheet.

Top sensing:

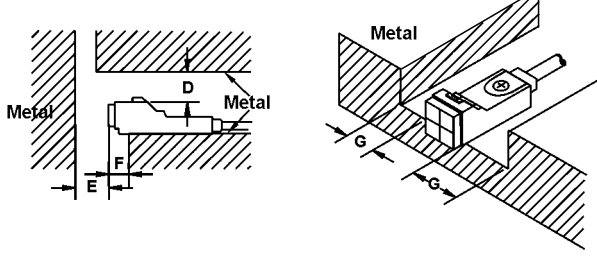

	MPS-6	MPS-8	MPS-15	MPS-15L
D	3mm	4mm	6mm	12mm
E	10mm	10mm	20mm	30mm
F	2mm	3mm	0mm	10mm *
G	2mm	3mm	3mm	10mm

\*: When the MPS-15L is mounted on an insulator or a nonferrous metal, or seated on the attached aluminum sheet, the separation distance "F" can be neglected.

## DC 2-wire type connection

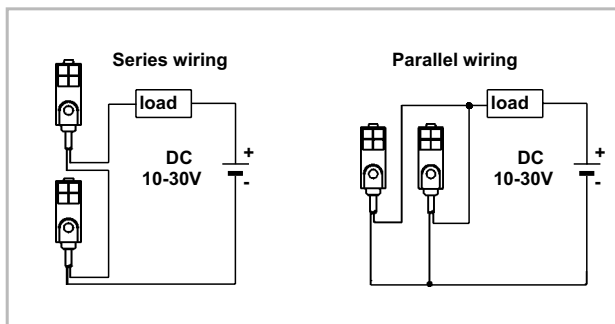

## Crosstalk prevention

.When two or more sensors are installed in parallel or face to face, keep the separation distance specified below at the minimum to avoid crosstalk.

Front sensing:

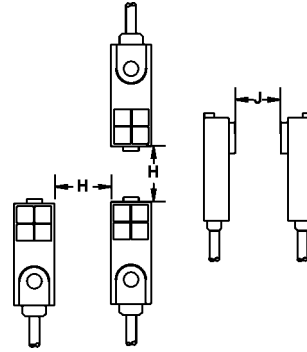

Top sensing:

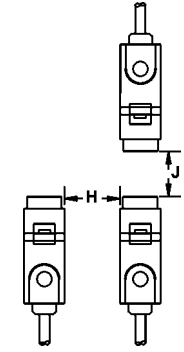

	MPS-6	MPS-8	MPS-12	MPS-15	MPS-15L
H	13mm	12mm	20mm	25mm	25mm
J	25mm	30mm	40mm	60mm	90mm

## Sensing range

.The sensing range is specified with using the standard sensing object. With a non-ferrous object, the sensing range is obtained by multiplying the correction coefficient specified below. (When an object is plated, the sensing range differs.)

Correction coefficient 1:

Model No.	MPS-6	MPS-8 (2-Way)	MPS-8 (3-Way)	MPS-12
Iron steel	1	1	1	1
Stainless steel	appror. 0.76	appror. 0.82	appror. 0.76	appror. 0.70
Brass	appror. 0.55	appror. 0.59	appror. 0.50	appror. 0.40
Aluminum	appror. 0.52	appror. 0.57	appror. 0.48	appror. 0.35

Correction coefficient 2:

Model No.	MPS-15 (2-Way)	MPS-15 (3-Way)	MPS-15L (2-Way)	MPS-15L (3-Way)
Iron steel	1	1	1	1
Stainless steel	appror. 0.74	appror. 0.68	appror. 0.75	appror. 0.76
Brass	appror. 0.53	appror. 0.47	appror. 0.53	appror. 0.50
Aluminum	appror. 0.52	appror. 0.45	appror. 0.51	appror. 0.48

## Standard sensing object

MPS-6	MPS-8	MPS-12	MPS-15	MPS-15L
iron steel 12 x 12 x t1mm	iron steel 15 x 15 x t1mm	iron steel 20 x 20 x t1mm	iron steel 20 x 20 x t1mm	iron steel 30 x 30 x t1mm

# DIMENSIONS (Unit : mm)

## MPS-6 (Front sensing)

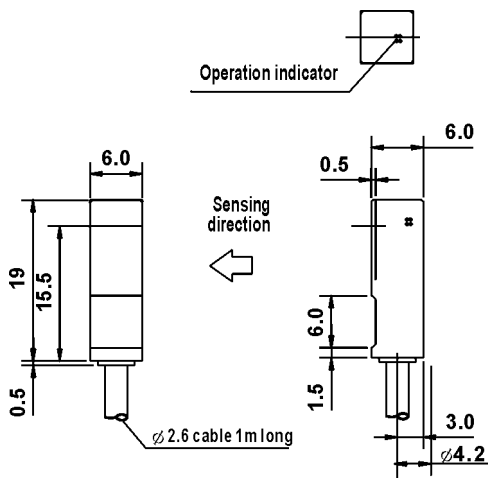

## MPS-6 (Top sensing)

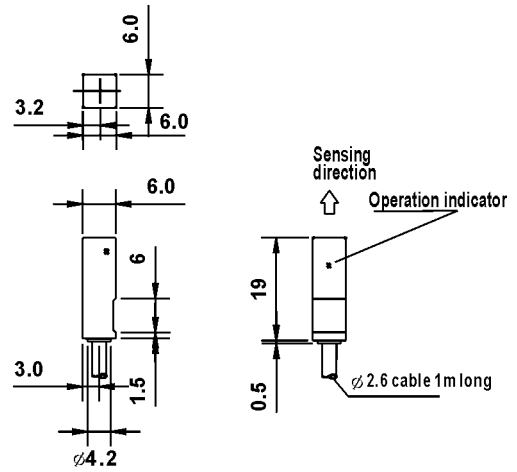

## MPS-8 (Front sensing)

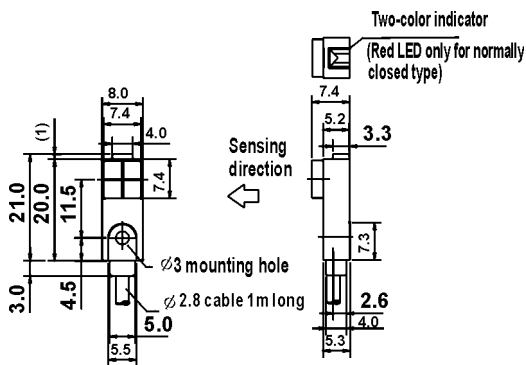

## MPS-8 (Top sensing)

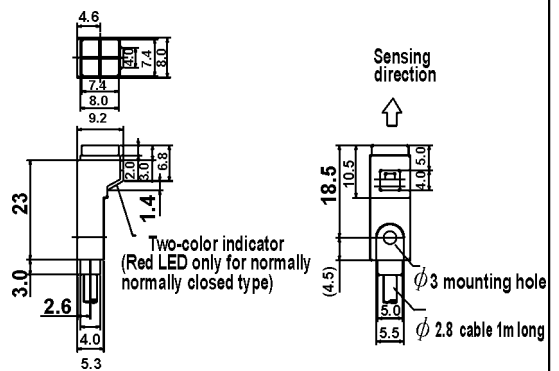

## MPS-12 (Front sensing)

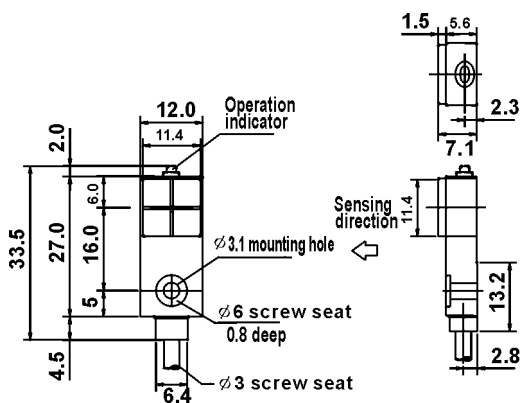

## MPS-12 (Connector)

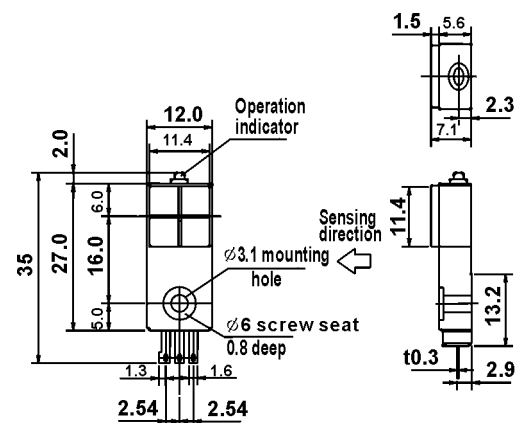

# DIMENSIONS (Unit : mm)

## MPS-15 (Front sensing)

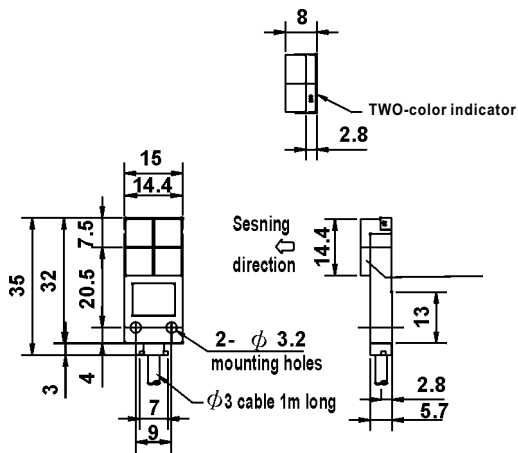

## MPS-15 (Top sensing)

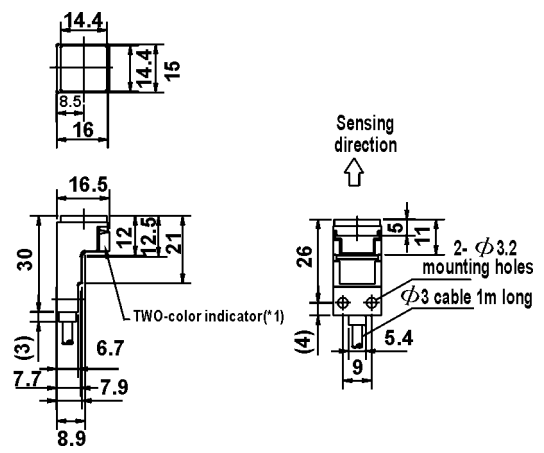

## SS-MPS6-1

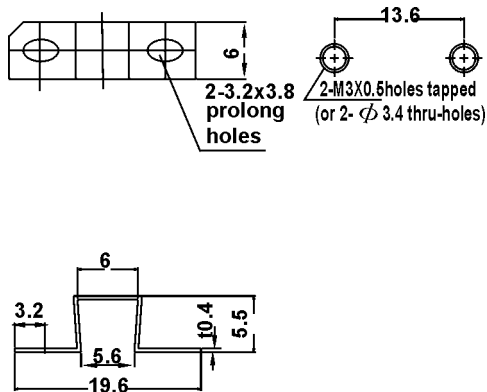

## SS-MPS6-2

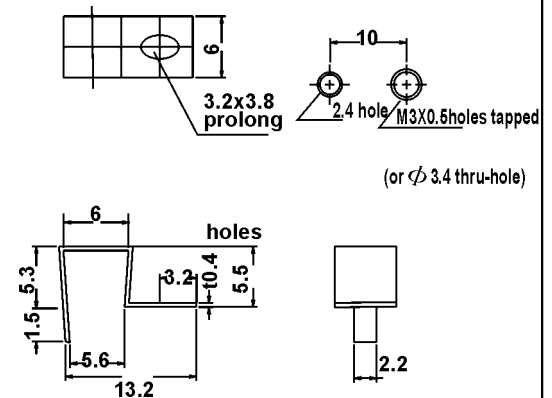

## SS-MPS8-4

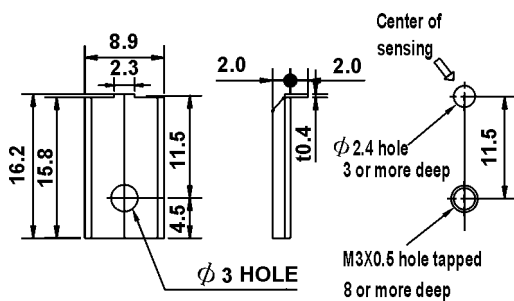

Material: spcc (Nickel plated)  
M3x12mm truss head screw, nut spring washer and flat washer are attached one each

## SS-MPS8

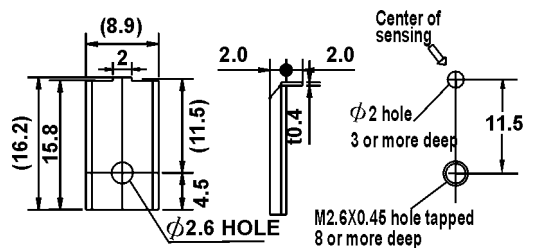

Material: SPCC (Nickel plated)  
M2.6x12mm truss head screw, nut spring washer and flat washer are attached one each

# DIMENSIONS (Unit : mm)

## SS-MPS12-1

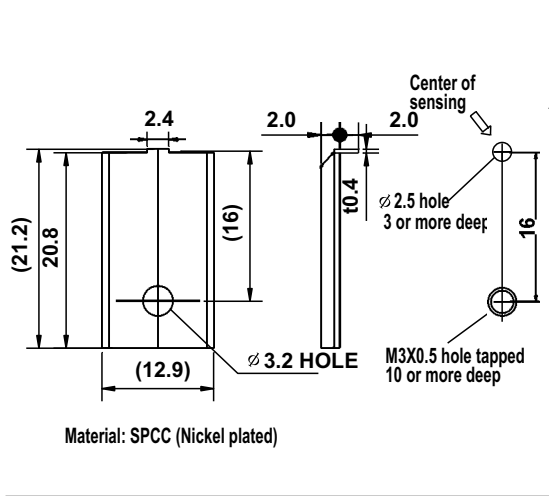

## SS-R1

Rubber washer for mps-12 type

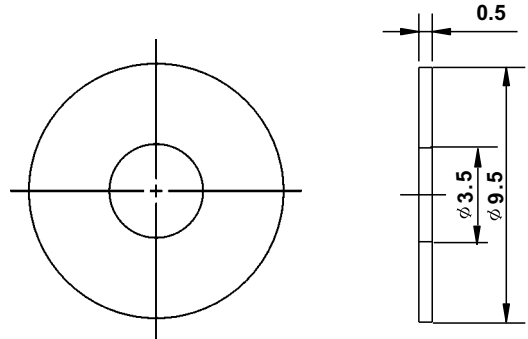

## SS-MPS8-3

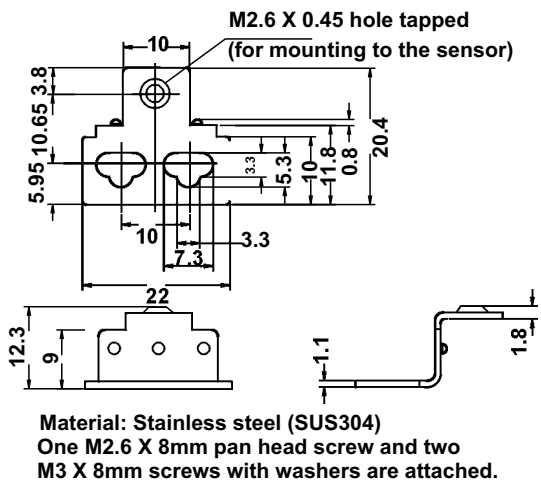

## SS-MPS12-2

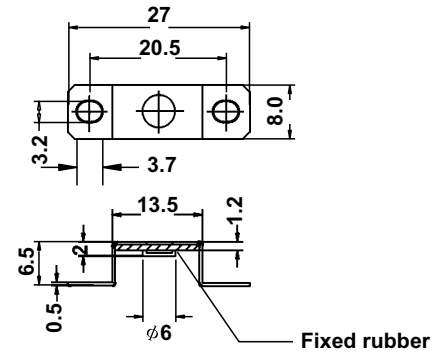

## SS-MPS15

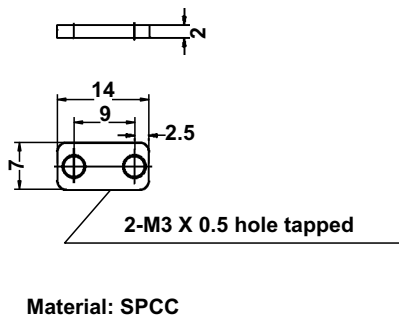

## SS-MPS15-2

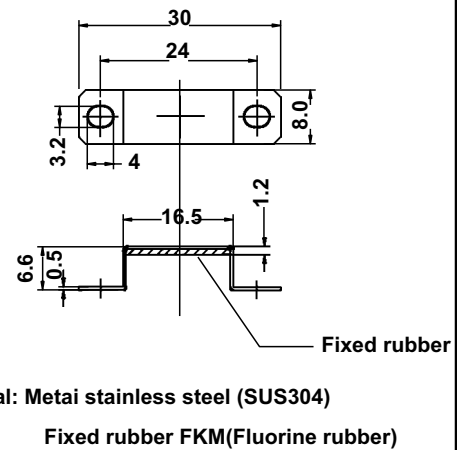

# DIMENSIONS (Unit : mm) AND SENSING CHARACTERISTICS

SN-13

SS-A15F/SS-A15H

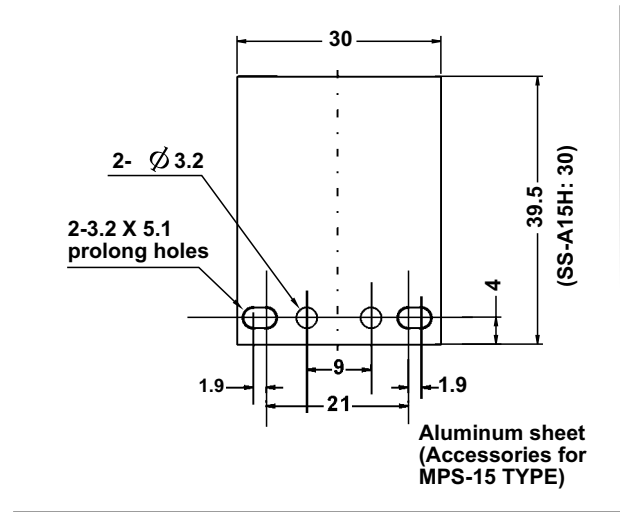
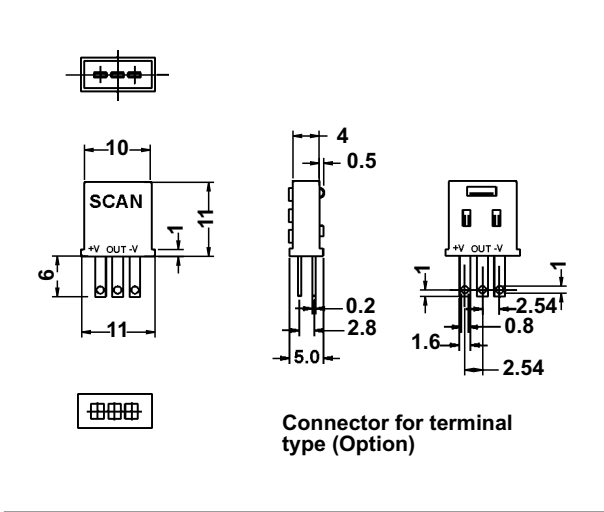

## TYPICAL SENSING CHARACTERISTICS

(These are typical sensing range, and are subject to slight changes from model to model.)

. Sensing range characteristics

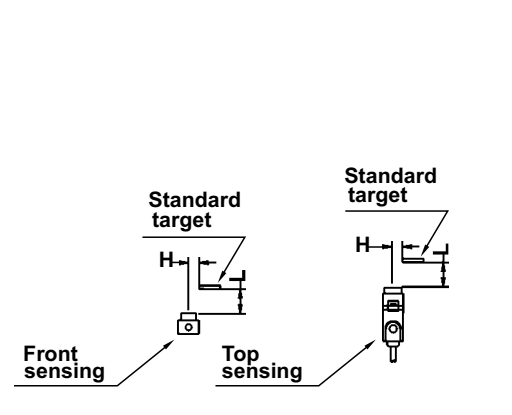
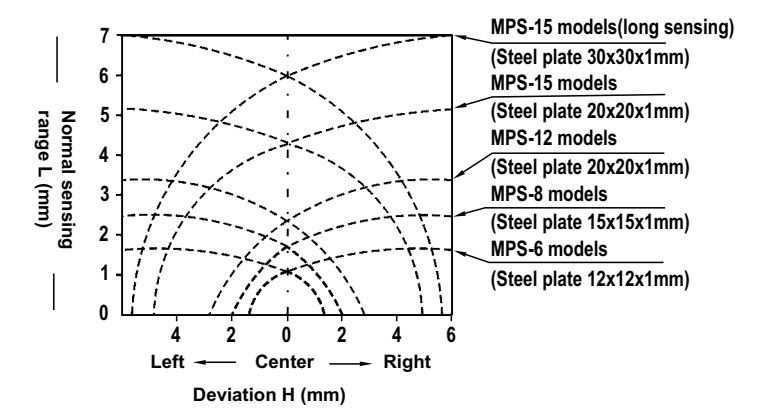

. Target size - Sensing range correlation

