

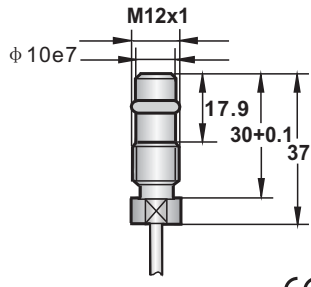





DC HIGH PRESSURE RATED SENSORS

WELD FIELD IMMUNE

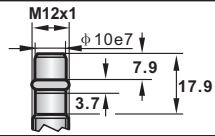
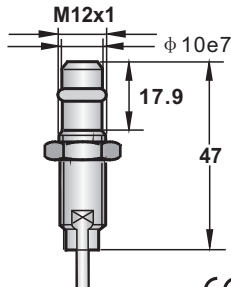
DC HIGH PRESSURE RATED SENSORS
---WELD FIELD IMMUNE

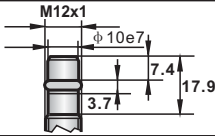
M12	
●	
1.5 mm	
SUS 303 stainless steel	
○	
	
CE 	
10-30VDC	
<10%	
< 10mA	
200mA	
<0.01mA	
≤ 1.0V	
2000Hz	
0.1ms/0.1ms	
<15%(Sr)	
< 1%(Sr)	
IP 68	
-25...+70°C	
<10%(Sr)	
YES	
220mA	
YES	
RFI>3V/m / EFT>1KV / ESD>4KV (contact)	
IEC 60947-5-2,Part 7.4.1 / IEC 60947-5-2,Part 7.4.2	
EPOXY	
DC13	
350 bar	
PCU1-121.5N-A3U2/37	1
PCU1-121.5N-B3U2/37	2
PCU1-121.5P-A3U2/37	3
PCU1-121.5P-B3U2/37	4
Installatin:	
	
4 φ 3x0.15	
Approx.60 g	

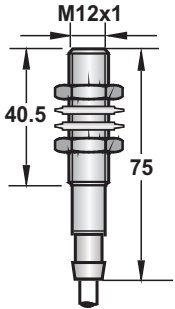
M12	
●	
1.5 mm	
SUS 303 stainless steel	
○	
	
CE 	
10-30VDC	
<10%	
< 10mA	
200mA	
<0.01mA	
≤ 1.0V	
2000Hz	
0.1ms/0.1ms	
<15%(Sr)	
< 1%(Sr)	
IP 68	
-25...+70°C	
<10%(Sr)	
YES	
220mA	
YES	
RFI>3V/m / EFT>1KV / ESD>4KV (contact)	
IEC 60947-5-2,Part 7.4.1 / IEC 60947-5-2,Part 7.4.2	
EPOXY	
DC13	
100 bar	
Installatin:	
	
4 φ 3x0.15	
Approx.67 g	

M12	
●	
2 mm	
SUS 303 stainless steel	
○	
	
CE 	
10-30VDC	
<10%	
< 10mA	
200mA	
<0.01mA	
≤ 1.5V	
2000Hz	
0.1ms/0.1ms	
<15%(Sr)	
< 1%(Sr)	
IP 68	
-25...+70°C	
<10%(Sr)	
YES	
220mA	
YES	
RFI>3V/m / EFT>1KV / ESD>4KV (contact)	
IEC 60947-5-2,Part 7.4.1 / IEC 60947-5-2,Part 7.4.2	
EPOXY	
DC13	
10 bar	
Installatin:	
	
4 φ 3x0.15	
Approx.97 g	

DC HIGH PRESSURE RATED SENSORS

WELD FIELD IMMUNE

DC HIGH PRESSURE RATED SENSORS
---WELD FIELD IMMUNE

M18
●
3 mm
SUS 303 stainless steel
○

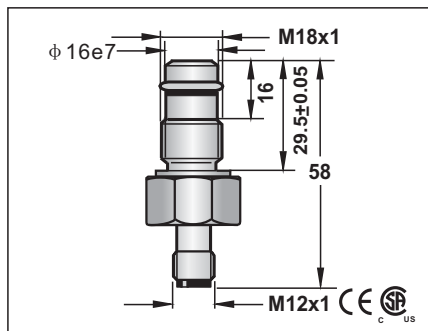

10-30VDC
<10%
< 10mA
200mA
<0.01mA
≤ 1.5V
1000Hz
0.2ms/0.2ms
<15%(Sr)
< 1%(Sr)
IP 68
-25...+80°C
<10%(Sr)
YES
220mA
YES
RFI>3V/m / EFT>1KV / ESD>4KV (contact)
IEC 60947-5-2,Part 7.4.1 / IEC 60947-5-2,Part 7.4.2
EPOXY
DC13
500 bar

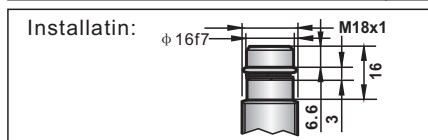

Approx.78 g

M18
●
3 mm
SUS 303 stainless steel
○

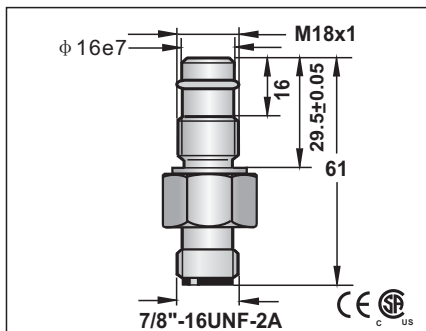

10-30VDC
<10%
< 10mA
200mA
<0.01mA
≤ 1.5V
1000Hz
0.2ms/0.2ms
<15%(Sr)
< 1%(Sr)
IP 68
-25...+80°C
<10%(Sr)
YES
220mA
YES
RFI>3V/m / EFT>1KV / ESD>4KV (contact)
IEC 60947-5-2,Part 7.4.1 / IEC 60947-5-2,Part 7.4.2
EPOXY
DC13
500 bar

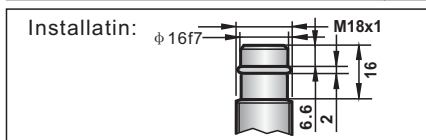

Approx.80 g

M18
●
1.5 mm
SUS 303 stainless steel
○

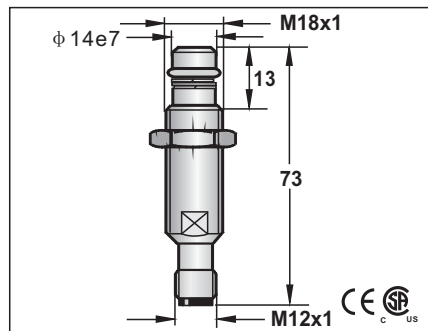

10-30VDC
<10%
< 10mA
200mA
<0.01mA
≤ 1.5V
1000Hz
0.2ms/0.2ms
<15%(Sr)
< 1%(Sr)
IP 68
-25...+80°C
<10%(Sr)
YES
220mA
YES
RFI>3V/m / EFT>1KV / ESD>4KV (contact)
IEC 60947-5-2,Part 7.4.1 / IEC 60947-5-2,Part 7.4.2
EPOXY
DC13
350 bar

PCU1-D181.5N-ARU4/73	33
PCU1-D181.5N-BRU4/73	34
PCU1-D181.5P-ARU4/73	35
PCU1-D181.5P-BRU4/73	36

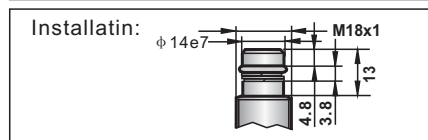

Approx.90 g