

Silicon Pressure Sensors

Uncompensated/Compensated
and Compensated Calibrated

*CPC, CPCL,
CPX, CPXL Series*

FEATURES

- Low Cost, Small Size
- Temperature Compensated
- Zero and Span Calibrated
- Millivolt Output
- Differential, Gage and Absolute Pressure
- Constant Voltage Excitation
- High Impedance - Low Current

TYPICAL APPLICATIONS

- Medical Applications
- Applications Requiring Small Size
- Applications Requiring Vacuum and Positive
- Pressure Reference, or Both



GENERAL DESCRIPTION

The CPX/CPXL and the CPC/CPCL Series sensors integrate silicon micromachined sensing technology, temperature compensation, and calibration in a complete family of low cost packages. This series offers the most cost-effective solution for design requirements.

These piezoresistive pressure sensors use micromachined silicon chips mounted on a ceramic and protected with a plastic cap. Several tube arrangements with nylon housings are available for various pressure applications.

On devices of 5 psi and above, the top side of the chip is protected against humidity by a Silgel coating. While the sensors are designed for use with non-corrosive, nonionic pressure media, they accommodate many gases that are used in medical applications.

The CPC Series is designed for the lowest cost and smallest profile. The standard packages have only a plastic cap for OEM applications. The CPC axial port option accommodates pressure measurements in tube applications.

WARNING

PERSONAL INJURY

DO NOT USE these products as safety or emergency stop devices or in any other application where failure of the product could result in personal injury.

Failure to comply with these instructions could result in death or serious injury.

WARNING

MISUSE OF DOCUMENTATION

- The information presented in this product sheet is for reference only. Do not use this document as a product installation guide.
- Complete installation, operation, and maintenance information is provided in the instructions supplied with each product.

Failure to comply with these instructions could result in death or serious injury.

Silicon Pressure Sensors

Uncompensated/Compensated
and Compensated Calibrated

CPC, CPCL
CPX, CPXL Series

ELECTRICAL SPECIFICATIONS

	CPC and CPCL @ 12 Vdc, 25 °C [77 °F]			CPX and CPXL CPCL @ 5 Vdc, 25 °C [77 °F]			Units
	Min.	Typ.	Max.	Min.	Typ.	Max.	
Excitation Voltage	3.0	12.0	16.0	3.0	5.0	12.0	Vdc
Null	-1.0	0	1.0	-50	0	50	mV
Offset Temperature Shift 0 °C to 70 °C [32 °F to 158 °F]**	--	--	±1.0	--	±0.5		mV
Full Scale Temperature Shift 0 °C to 70 °C [32 °F to 158 °F] ²	--	--	±2	--	-2050 PPM/°C	--	% Span
Linearity, Hysteresis Error ³	--	0.25	1.0		0.25	1.0	% Span
Input Resistance	5.0	--	--	5.0	--	--	kΩ
Output Resistance	--	3.0	--	--	3.0	--	kΩ
Operating Temperature	-25 [-13]	--	85 [185]	-25 [-13]	--	85 [185]	°C [°F]
Storage Temperature	-40 [-40]	--	125 [257]	-40 [-40]	--	125 [257]	°C [°F]
Common Mode Pressure	--	--	50	--	--	50	psi
Weight	--	2	--	--	2	--	gram

Note 1: Pressure specs obtained with pressure applied to the front of the sensor.

Note 2: Shift is relative to 25 °C [77 °F]

Note 3: Measured at ½ full scale rated pressure using BFSL

ABSOLUTE OUTPUT

FS Pressure	CPC @ 12 Vdc, 25 °C [77 °F] Output Full Scale Span, (mV)			CPX @ 12 Vdc, 25 °C [77 °F] Output Full Scale Span, (mV)			Overpressure (Psi)
	Min.	Typ.	Max.	Min.	Typ.	Max.	Max.
5 psi	57	60	63	112	168.5	225	15 psi
15 psi	85	90	95	168	253	338	45 psi
30 psi	85	90	95	168	253	338	90 psi
60 psi	85	90	95	189	263.5	338	180 psi
100 psi	95	100	105	210	295	380	250 psi
150 psi	85	90	95	--	--	--	250 psi

GAGE AND DIFFERENTIAL1 OUTPUT

FS Pressure	CPC and CPCL @ 12 Vdc, 25 °C [77 °F] Output Full Scale Span, (mV)			CPX and CPXL @ 12 Vdc, 25 °C [77 °F] Output Full Scale Span, (mV)			Overpressure (Psi)
	Min.	Typ.	Max.	Min.	Typ.	Max.	Max.
4 in H2O	23	25	27	50	68	86	3
10 in H2O	19	20	21	45	78.5	112	3
1 psi	17	18	19	40	75	110	3
5 psi	57	60	63	112	168.5	225	15
15 psi	85	90	95	168	253	338	45
30 psi	85	90	95	168	253	338	90
60 psi	85	90	95	189	263.5	338	180
100 psi	95	100	105	210	295	380	250
150 psi	85	90	95	187	262.5	338	250

Note 1: Differential common mode pressure should not exceed 50 psi

Silicon Pressure Sensors

Uncompensated/Compensated
and Compensated Calibrated

*CPC, CPCL
CPX, CPXL Series*

PHYSICAL DIMENSIONS for reference only mm [In]

Non-ported Package

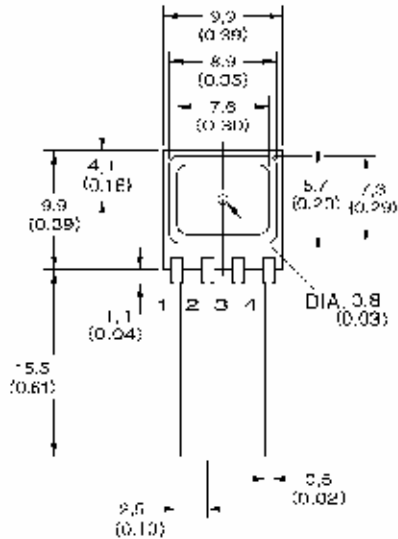

AF and GF Package

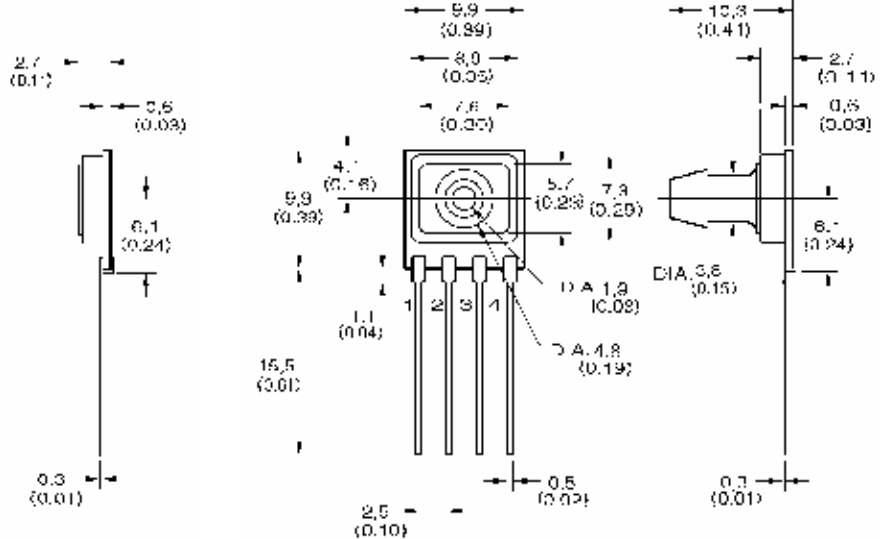

DF Package

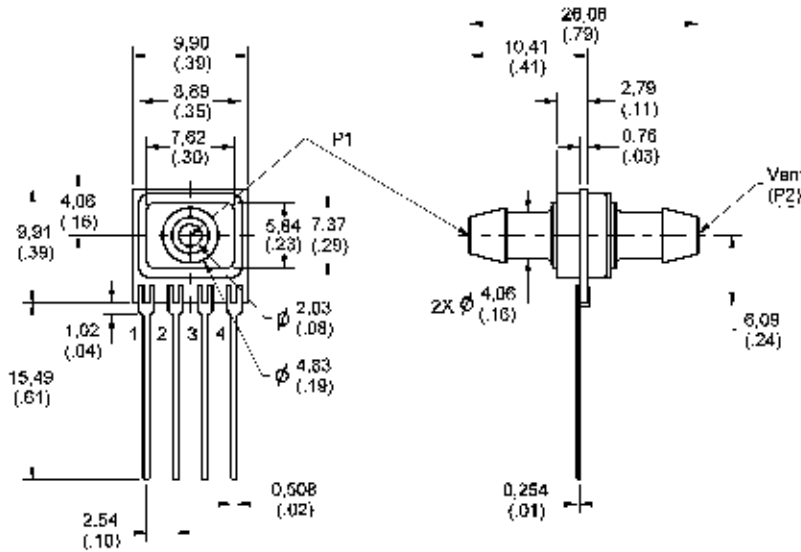

EQUIVALENT CIRCUIT

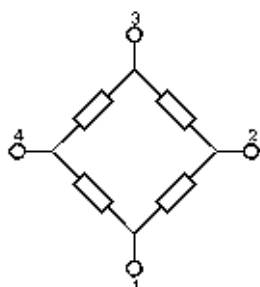

Pinout

1. - V Excitation
2. + Output Signal
3. +V Excitation
4. - Output Signal

MEDIA COMPATIBILITY:

Clean, dry gases only

P1 Port: Media must be compatible with epoxy based adhesive.

P2 Port: Media must be compatible with nylon housing, epoxy adhesive and silicon.

Silicon Pressure Sensors

Uncompensated/Compensated
and Compensated Calibrated

*CPC, CPCL
CPX, CPXL Series*

CPC/CPCL/CPX/CPXL SERIES ORDER GUIDE

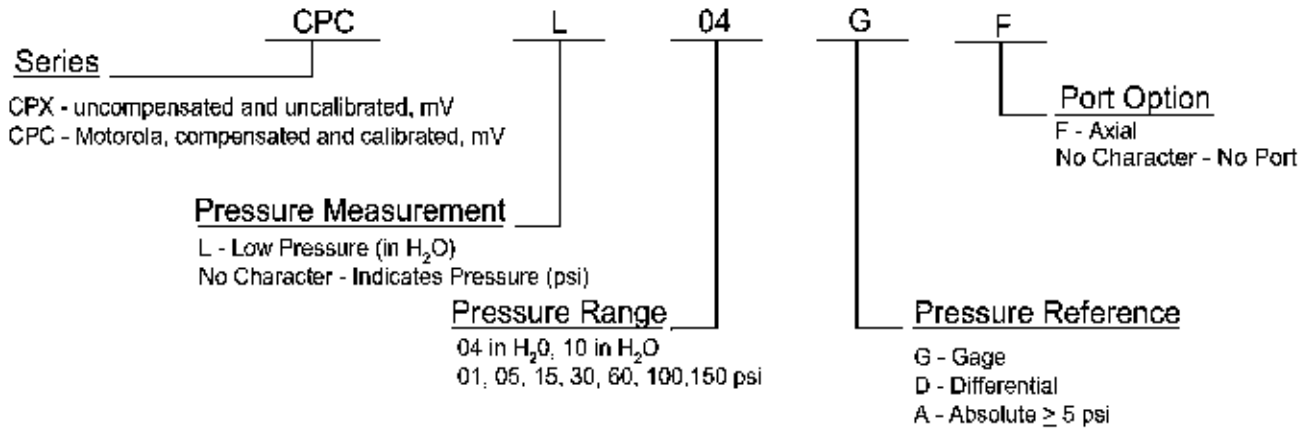

WARRANTY/REMEDY

Honeywell warrants goods of its manufacture as being free of defective materials and faulty workmanship. Contact your local sales office for warranty information. If warranted goods are returned to Honeywell during the period of coverage, Honeywell will repair or replace without charge those items it finds defective. **The foregoing is Buyer's sole remedy and is in lieu of all other warranties, expressed or implied, including those of merchantability and fitness for a particular purpose.**

Specifications may change without notice. The information we supply is believed to be accurate and reliable as of this printing. However, we assume no responsibility for its use.

While we provide application assistance personally, through our literature and the Honeywell web site, it is up to the customer to determine the suitability of the product in the application.

For application assistance, current specifications, or name of the nearest Authorized Distributor, contact a nearby sales office. Or call:

1-800-537-6945 USA/Canada

1-815-235-6847 International

FAX

1-815-235-6545 USA

INTERNET

www.honeywell.com/sensing

info.sc@honeywell.com

Honeywell

Sensing and Control

www.honeywell.com/sensing

Honeywell

11 West Spring Street

Freeport, Illinois 61032