

Solid State Hall-effect Sensors

Active High/Active Low Complementary
Output Hall-effect Latch

SS42R Series

FEATURES

- Digital dual complementary sink/source outputs
- Reverse Voltage Polarity protection for full supply range.
- Operate/release points are trimmed for zero symmetry
- High output current capability
- Small 4-pin SIP package

TYPICAL APPLICATIONS

- Conveyors
- Motor control
- Ignition timing
- Power sensing
- Linear or rotary motion detection
- RPM sensing



The SS42R Series is a Bipolar Latching Hall IC with a pair of complementary push/pull outputs. A dual Hall element is used to offset stress induced noise and drift. The operate and release points are laser trimmed to insure near-zero symmetry. The robust outputs are capable of sourcing up to 6.4 mA and sinking up to 4.4 mA. The device contains inherent reverse polarity protection up to the full power supply rating.

⚠ WARNING

PERSONAL INJURY

DO NOT USE these products as safety or emergency stop devices or in any other application where failure of the product could result in personal injury.

Failure to comply with these instructions could result in death or serious injury.

⚠ WARNING

MISUSE OF DOCUMENTATION

- The information presented in this product sheet is for reference only. Do not use this document as a product installation guide.
- Complete installation, operation, and maintenance information is provided in the instructions supplied with each product.

Failure to comply with these instructions could result in death or serious injury.

Solid State Hall-effect Sensors

Active High/Active Low Complementary
Output Hall-effect Latch

SS42R Series

ABSOLUTE MAXIMUM RATINGS ^(Note 1)

Parameter	Min	Max	Unit	Conditions
Temperature	-40	125	°C	Storage, no power applied
Supply Voltage (Vs)	-28	28	V	0 °C to 100 °C [32 °F to 212 °F]
Voltage Externally Applied to Output	-1.2	5	V	0 °C to 100 °C [32 °F to 212 °F]
Output Current	-10	10	mA	
Magnetic Flux	–	–	–	No limit; the circuit cannot be damaged by magnetic overdrive

Note:

1. Absolute maximum ratings are the extreme limits that the device will withstand without damage to the device. However, the electrical and magnetic characteristics are not guaranteed as the maximum limits (above recommended operating conditions) are approached nor will the device necessarily operate at absolute maximum rating.

ELECTRICAL CHARACTERISTICS

Parameter	24 °C ± 2 °C [75.2 °F ± 2 °F]		0 °C to 75 °C [32 °F to 167 °F]		Unit	Conditions
	Min	Max	Min	Max		
Supply Current	11.0		12.0		mA	28 V ± 0.5% supply
Output Voltage						
#1 Sourcing	5.0	6.0	–	–	mA	Switch magnetically operated: No load 28 V ± 0.5% supply. Switch magnetically released: No load 28 V ± 0.5% supply.
#2 Sinking	0	0.2	–	–		
#1 Sinking	0	0.2	–	–		
#2 Sourcing	5.0	6.0	–	–		
Leakage (sink)	1.0		1.0		µA	Apply voltage 0.2 V greater than measured output source voltage measure current, no load 28 V ± 0.5% supply.
Output Current						
#1 Sourcing	4.0	6.5	3.75	6.4	mA	Apply 2 V to output and measure current. Switch magnetically operated, no load 28 V ± 0.5%. Apply 2 V to output and measure current. Switch magnetically released, no load 28 V ± 0.5%
#2 Sinking	2.8	4.7	2.4	4.4		
#1 Sinking	2.8	4.7	2.2	4.4		
#2 Sourcing	4.0	6.5	3.75	6.4		
Output Switching Time						
Fall Time	–	–	1.0		µs	90 % to 10 %; no load 28 V ± 0.5% supply 10 % to 90 %; no load 28 V ± 0.5% supply
Rise Time	–	–	1.0			

MAGNETIC CHARACTERISTICS ^(Note 1)

Parameter	24 °C ± 2 °C [75.2 °F ± 2 °F] Vs=12 Vdc ± 0.5% Vdc		0 °C to 75 °C [32 °F to 167 °F] Vs=4.5 Vdc to 28 Vdc		0 °C to 100 °C [32 °F to 212 °F] Vs=4.5 Vdc to 16 Vdc	
	Min	Max	Min	Max	Min	Max
Operate Point	55	185	40	250	40	350
Release Point	-185	-55	-250	-40	-350	-40
Differential	200	300	150	420	150	600

Note:

1. The magnetic field strength (gauss) required to cause the switch to change state (operate and release) will be as specified in the magnetic characteristics. To test the switch against the specified magnetic characteristics the switch must be placed in a uniform magnetic field.

Solid State Hall-effect Sensors

Active High/Active Low Complementary
Output Hall-effect Latch

SS42R Series

BLOCK DIAGRAM

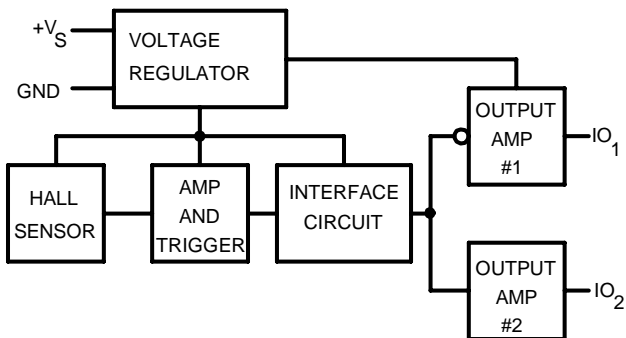
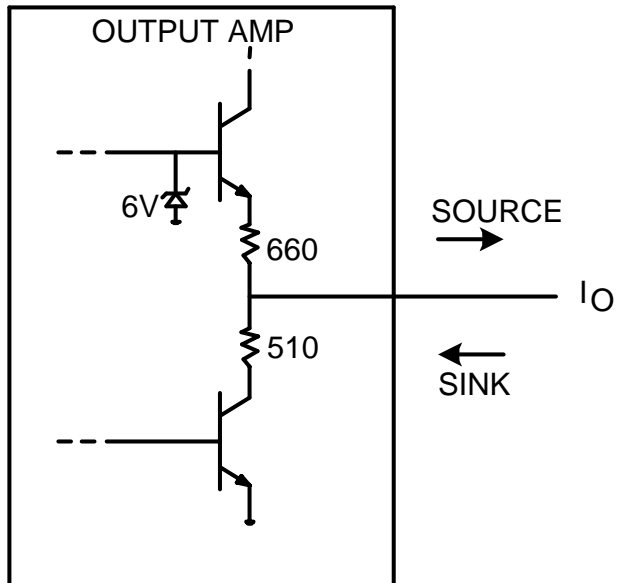

Solid State Hall-effect Sensors

Active High/Active Low Complementary Output Hall-effect Latch

SS42R Series

SS42 SERIES MOUNTING DIMENSIONS mm/[in] (for reference only)

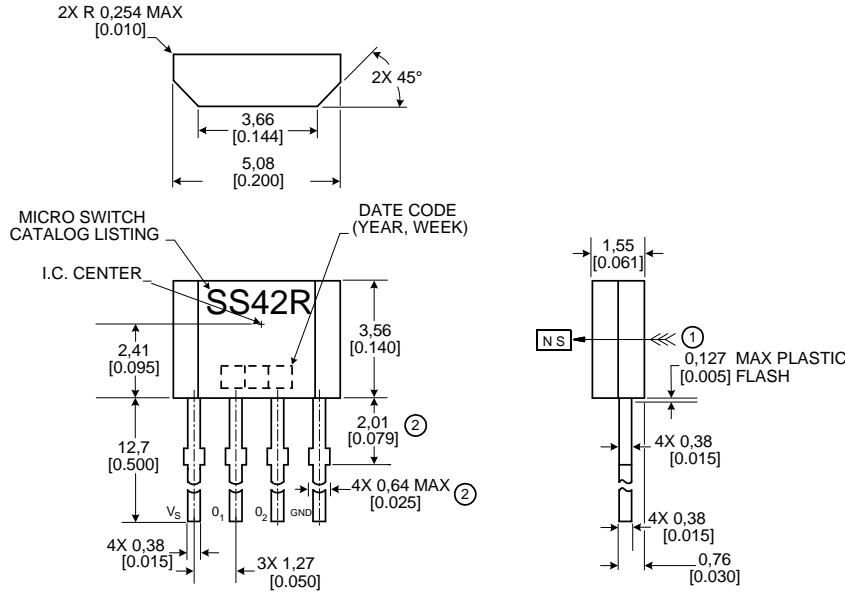

ORDER GUIDE

Catalog Listing	Description
SS42R	Active High/Active Low Complementary Output Hall-effect Latch

WARRANTY/REMEDY

Honeywell warrants goods of its manufacture as being free of defective materials and faulty workmanship. Contact your local sales office for warranty information. If warranted goods are returned to Honeywell during the period of coverage, Honeywell will repair or replace without charge those items it finds defective. **The foregoing is Buyer's sole remedy and is in lieu of all other warranties, expressed or implied, including those of merchantability and fitness for a particular purpose.**

Specifications may change without notice. The information we supply is believed to be accurate and reliable as of this printing. However, we assume no responsibility for its use.

While we provide application assistance personally, through our literature and the Honeywell web site, it is up to the customer to determine the suitability of the product in the application.

For application assistance, current specifications, or name of the nearest Authorized Distributor, contact a nearby sales office. Or call:

1-800-537-6945 USA/Canada

1-815-235-6847 International

FAX

1-815-235-6545 USA

INTERNET

www.honeywell.com/sensing

info.sc@honeywell.com

Honeywell

Sensing and Control

www.honeywell.com/sensing

Honeywell

11 West Spring Street

Freeport, Illinois 61032