

SS41F/SS41G Series

Low-Cost Digital Bipolar Hall-Effect Sensor ICs

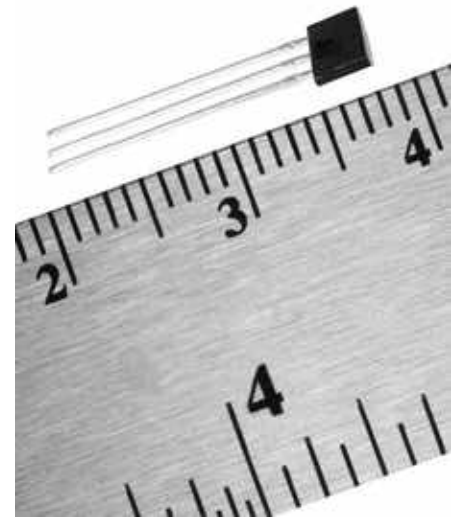

DESCRIPTION

The SS41F/SS41G Series are small, versatile digital Hall-effect devices that are operated by the magnetic field from a permanent magnet or an electromagnet, and are designed to respond to alternating North and South poles.

A built-in regulator provides enhanced stability of operation over 4.5 Vdc to 24 Vdc supply voltage range, and internal circuitry is designed to prevent sensor damage in case the supply voltage polarity is accidentally reversed.

FEATURES AND BENEFITS

- Small, leaded, flat TO-92-style package allows for a compact PCB layout
- Wide operating voltage range of 4.5 Vdc to 24 Vdc makes these sensors useable in a variety of applications
- Current consumption of only 5 mA max. at 4.5 Vdc for energy efficiency
- Bipolar magnetics for ring magnet applications with alternating North and South poles
- Robust design: will operate up to 150 °C [302 °F]
- RoHS-compliant materials meet Directive 2002/95/EC

The open-collector sinking output voltage is easily interfaced with a wide variety of electronic circuits.

The SS41F is factory tested at 25 °C [77 °F] and the SS41G is factory tested at both 25 °C [77 °F] and 125 °C [257 °F].

Both products are designed for high volume applications.

POTENTIAL APPLICATIONS

Transportation

- Speed and RPM sensing
- Commutation and control of electric motors used in transportation

Industrial and Commercial

- Flow-rate sensing for appliances
- Tachometer, counter pickup
- Brushless dc motor commutation
- Motor and fan control for commercial, consumer or industrial equipment

Medical

- Any medical equipment or instruments using electric motors

SS41F/SS41G Series

Table 1. SS41F Specifications (At $V_s = 4.5$ Vdc to 24 Vdc supply, 20 mA load, $T_a = 25$ °C [77 °F] unless otherwise noted.)

Characteristic	Condition	Min.	Typ.	Max.	Unit
Supply voltage	–	4.5	–	24.0	Vdc
Supply current	–	–	6.8	10.0	mA
Output current	–	–	–	20.0	mA
Vsat at 15 mA	$V_s = 12$ Vdc, Bop >170	–	–	0.4	V
Output leakage	$V_s = 24$ Vdc, Brp ≤170	–	–	10	μA
Rise time	$V_s = 4.5$ Vdc	–	0.5	1.5	μs
Fall time	$V_s = 4.5$ Vdc	–	0.2	1.5	μs
Operate (Bop)	–	–	40	150	Gauss
Release (Brp)	–	-150	-40	–	Gauss
Differential	–	40	–	–	Gauss
Operating temperature	–	-40 [-40]	–	150 [302]	°C [°F]
Storage temperature	–	-40 [-40]	–	150 [302]	°C [°F]

Table 2. SS41G Specifications (At $V_s = 4.5$ Vdc to 24 Vdc, 20 mA load, $T_a = -40$ °C to 150 °C [-40 °F to 302 °F] unless otherwise noted.)

Characteristic	Condition	Min.	Typ.	Max.	Unit
Supply voltage	–	4.5	–	24.0	Vdc
Supply current	output OFF	–	6.8	10.0	mA
Supply current	output ON	–	–	11.3	mA
Output current	–	–	–	20.0	mA
Vsat at 20 mA	25 °C [77 °F], $V_s = 12$ Vdc, Bop >170	–	–	0.4	V
Output leakage	$V_s = 24$ Vdc, Gauss ≤170	–	–	10	μA
Rise time	25 °C [77 °F]	–	0.5	1.5	μs
Fall time	25 °C [77 °F]	–	0.2	1.5	μs
Operate (Bop)	25 °C [77 °F]	–	40	150	Gauss
Operate (Bop)	–	–	–	250	Gauss
Release (Brp)	25 °C [77 °F]	-140	-40	–	Gauss
Release (Brp)	–	-250	–	–	Gauss
Differential	–	40	–	–	Gauss
Operating temperature	–	-40 [-40]	–	150 [302]	°C [°F]
Storage temperature	–	-40 [-40]	–	150 [302]	°C [°F]

NOTICE

Bipolar Hall-effect sensor ICs may have an initial output in either the ON or OFF state if powered up with an applied magnetic field in the differential zone (applied magnetic field >Brp and <Bop). Honeywell recommends allowing 10 μs for output voltage to stabilize after supply voltage has reached its rated value.

NOTICE

The magnetic field strength (Gauss) required to cause the switch to change state (operate and release) will be as specified in the magnetic characteristics. To test the switch against the specified magnetic characteristics, the switch must be placed in a uniform magnetic field.



Table 3. SS41F/SS41G Series Absolute Maximum Ratings¹

Characteristic	Min.	Typ.	Max.	Unit
Supply voltage	-28.0	–	28.0	V
Applied output voltage	-0.5	–	28.0	V
Output current	–	–	20	mA
Magnetic flux	–	–	no limit	Gauss

Note 1: Absolute maximum ratings are the extreme limits that the device will withstand without damage to the device. However, the electrical and mechanical characteristics are not guaranteed as the maximum limits (above recommended operating conditions) are approached, nor will the device necessarily operate at absolute maximum ratings.

SS41F/SS41G Series Low Cost Digital Bipolar Hall-Effect Sensor ICs

Figure 1. Magnetic Performance vs Temperature

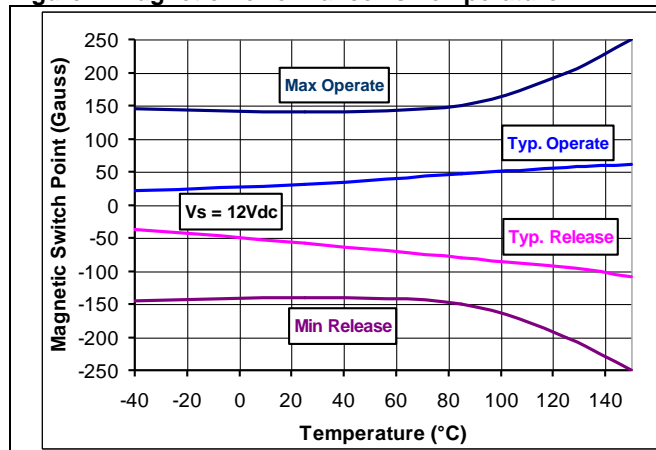

Figure 2. Current Sinking Output Block Diagram

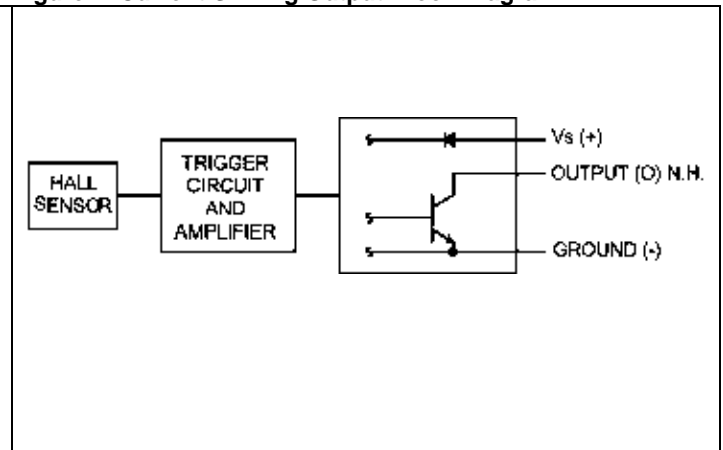

Figure 3. Wiring Diagrams

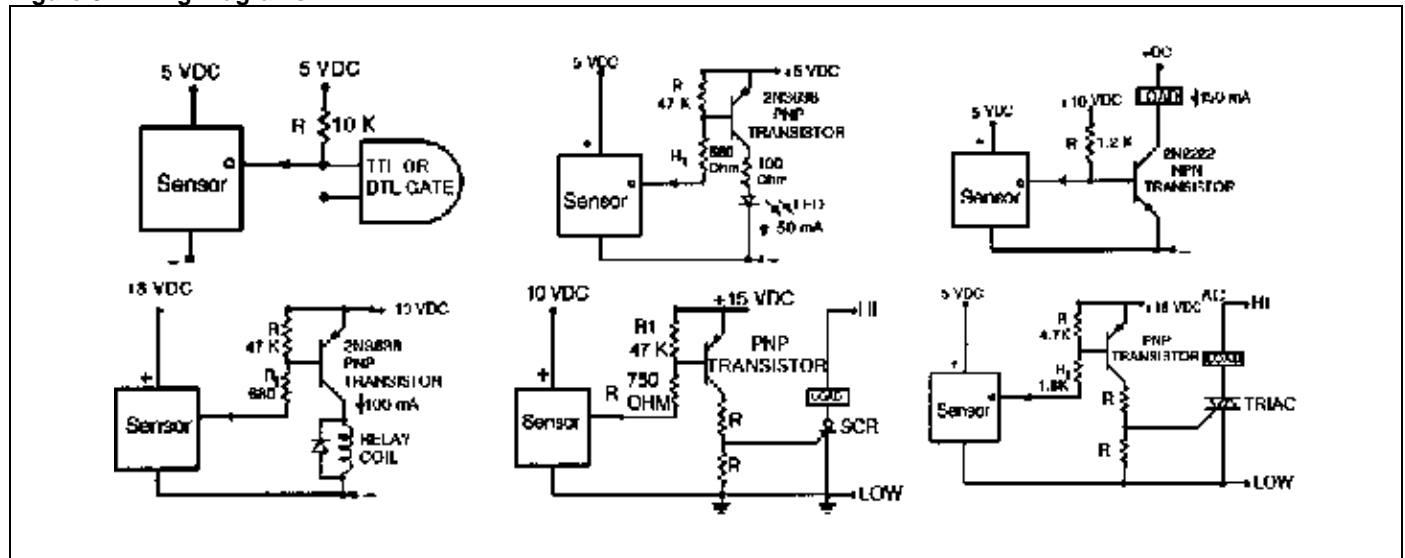
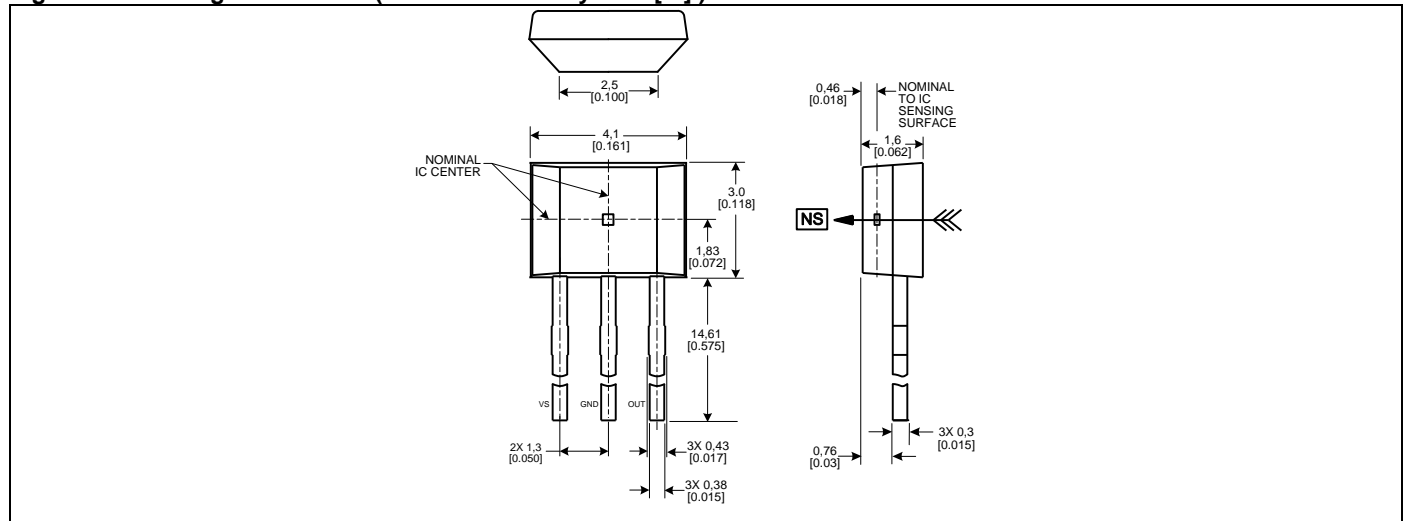

Figure 4. Mounting Dimensions (For reference only. mm/[in.])



Order Guide

Catalog Listing	Description
SS41F	Low-cost digital bipolar Hall-effect sensor IC, tested at 25 °C [77 °F], flat TO-92-style package, bulk packaging (1000 units per bag)
SS41G	Low-cost digital bipolar Hall-effect sensor IC, tested at 25 °C [77 °F] and 125 °C [257 °F], flat TO-92-style package, bulk packaging (1000 units per bag)

WARNING

PERSONAL INJURY

DO NOT USE these products as safety or emergency stop devices or in any other application where failure of the product could result in personal injury.

Failure to comply with these instructions could result in death or serious injury.

WARRANTY/REMEDY

Honeywell warrants goods of its manufacture as being free of defective materials and faulty workmanship. Honeywell's standard product warranty applies unless agreed to otherwise by Honeywell in writing; please refer to your order acknowledgement or consult your local sales office for specific warranty details. If warranted goods are returned to Honeywell during the period of coverage, Honeywell will repair or replace, at its option, without charge those items it finds defective. **The foregoing is buyer's sole remedy and is in lieu of all other warranties, expressed or implied, including those of merchantability and fitness for a particular purpose. In no event shall Honeywell be liable for consequential, special, or indirect damages.**

While we provide application assistance personally, through our literature and the Honeywell web site, it is up to the customer to determine the suitability of the product in the application.

Specifications may change without notice. The information we supply is believed to be accurate and reliable as of this printing. However, we assume no responsibility for its use.

WARNING

MISUSE OF DOCUMENTATION

- The information presented in this product sheet is for reference only. Do not use this document as a product installation guide.
- Complete installation, operation, and maintenance information is provided in the instructions supplied with each product.

Failure to comply with these instructions could result in death or serious injury.

SALES AND SERVICE

Honeywell serves its customers through a worldwide network of sales offices, representatives and distributors. For application assistance, current specifications, pricing or name of the nearest Authorized Distributor, contact your local sales office or:

E-mail: info.sc@honeywell.com

Internet: www.honeywell.com/sensing

Phone and Fax:

Asia Pacific	+65 6355-2828 +65 6445-3033 Fax
Europe	+44 (0) 1698 481481 +44 (0) 1698 481676 Fax
Latin America	+1-305-805-8188 +1-305-883-8257 Fax
USA/Canada	+1-800-537-6945 +1-815-235-6847 +1-815-235-6545 Fax

Sensing and Control
Honeywell
1985 Douglas Drive North
Golden Valley, MN 55422
www.honeywell.com/sensing

005889-2-EN IL50 GLO Printed in USA
October 2010
© 2010 Honeywell International Inc. All rights reserved.

Honeywell