

SMART Position Sensor, 100° and 180° Arc Configurations Superior Measurement. Accurate. Reliable. Thinking.



DESCRIPTION

The SMART Position Sensor is one of the most durable, adaptable, and lightweight linear position sensors available in the industry, enabling highly accurate motion control and improving operation efficiency and safety. Its simple, non-contact design eliminates mechanical failure mechanisms, reducing wear and tear, improving reliability and durability, and minimizing downtime.

The SMART Position Sensor is a non-contacting sensing solution for absolute position sensing with enhanced accuracy. It senses the position of a magnet relative to the sensor in one of two available sensing ranges:

- 0° to 100°
- 0° to 180°

Why is the SMART Position Sensor smart? SMART means that this is a sensor that can essentially think for itself. SMART Position Sensors provide a self-diagnostics feature and data gathering for enhanced reliability and closed-loop feedback control.

VALUE PROPOSITIONS (★ = competitive differentiator)

- ★ **Reliable, durable:** Non-contact design reduces wear and tear, improving reliability and durability, minimizing downtime
- ★ **Easy to install:** Installation takes 4 steps (1: position device; 2: drill holes 3: mount sensor; 4: locate magnet/connect sensor) vs. up to 14 steps some competitive products require, simplifying installation and reducing set-up costs
- **Rugged:** As there are no moving parts within sensor, Honeywell utilizes unique packaging materials that make it resistant to vibration, shock, and extreme temperatures
- ★ **Flexible:** Air gap tolerance of 7,8 ±2,5 mm [0.307 ±0.098 in] (100°) and 8,5 ±2,5 mm [0.338 ±0.098 in] (180°) between sensor and magnet expands application use
- ★ **Cost effective:** Adaptable, non-contacting design allows customers to eliminate unnecessary connections for installation, thereby reducing installation steps/time and components
- **Accurate:** 100° configuration accurately measures values down to 0.06° while the 180° configuration accurately measures values down to 0.11°
- ★ **Adaptable:** Electronics on board allow for flexible packaging and component compatibility with existing systems
- ★ **Lightweight:** Lighter in weight than optical encoders
- ★ **Self-diagnostics feature** can reduce equipment downtime by providing predictive maintenance input
- **Combined patented MR sensor and ASIC technology** provides enhanced differentiation and performance
- **IP67, IP69K sealing** allow use in many harsh applications
- **RoHS-compliant** materials meet Directive 2002/95/EC

They use a patented combination of an ASIC (Application-Specific Integrated Circuit) and an array of MR (magneto-resistive) sensors to accurately and reliably determine the position of a magnet attached to a moving object so that the object's position can be determined or controlled.

The MR array measures the output of the MR sensors mounted along the magnet's direction of travel. The output and the MR sensor sequence determine the nearest pair of MR sensors to the center of the magnet location. The output of these two MR sensors is then used to determine the position of the magnet between them.

With this sensor, Honeywell has utilized MR technology through the ASIC at a level never before accomplished.

Other configurations are in development.

SMART Position Sensor

POTENTIAL APPLICATIONS

Transportation

- Aerial work lift platform, front end loader and digger/excavator boom position
- Scissor lift position
- Refuse truck lift and automatic reach arm position
- Mobile crane steering
- Timber harvester/processor equipment cutter arm angle
- On-board loader weighing system position

Industrial

- Telescoping conveyor elevation
- Power generation contact angle
- Rail-road crossing arms position

Military

- Remote weapon systems elevation
- Chassis suspension systems position height
- Military vehicle door position

Aerospace:

- Ground-based solar panels elevation and azimuth
- Ground-based satellite dish elevation and azimuth

Medical:

- Robotically-assisted surgery equipment position
- Patient bed elevation

For more information on these potential applications, please see the application note "[SMART Position Sensor, 100° and 180° Arc Configurations](#)".

Table 1. Specifications

Characteristic	Component	Parameter			
		100° Arc		180° Arc	
		SPS-A100D-HAMS	SPS-A100D-VAMS	SPS-A180D-HAMS	SPS-A180D-VAMS
Sensing range	sensor only	0° to 100°		0° to 180°	
Resolution		0.06°		0.11°	
Supply voltage		6 Vdc to 24 Vdc	18 Vdc to 40 Vdc	6 Vdc to 24 Vdc	18 Vdc to 40 Vdc
Output		0.5 Vdc to 4.5 Vdc (10% to 90% of 5 Vdc)			
Supply current		45 mA max.			
Linearity		±0.4% full scale output			
Reverse polarity		26.4 Vdc	40 Vdc	26.4 Vdc	40 Vdc
Sensitivity		40 mV/° ±4% FS		22.22 mV/° ±4% FS	
Measurement frequency		312 Hz typ.			
Termination		4-pin, M12 connector			
Operating temperature	sensor and magnet actuator	-40 °C to 85 °C [-40 °F to 185 °F]			
Storage temperature		-40 °C to 150 °C [-40 °F to 302 °F]			
Air gap		7,8 ±2,5 mm [0.307 ±0.098 in]		8,58 ±2,5 mm [0.338 ±0.098 in]	
Sealing		IP67, IP69K			
Shock		50 G half sine wave with 11 ms duration			
Vibration		20 G from 10 Hz to 2000 Hz			
Housing material		thermoplastic			
Approvals		CE			
Mounting: screws recommended torque		M6 or 1/4-20 6 N m to 8 N m [53.1 in lb to 70.8 in lb]			
Material		magnet actuator only	neodymium		
Strength	10,000 Gauss				

Notes:

- Tolerance applies for full sense range.
- Device used to read analog output must have input impedance greater than 1 MOhm.
- The output voltage outside of the valid measurement range will be indeterminate.
- Percent linearity is the quotient of the measured output deviation from the best fit line at the measured temperature to the full scale output span.

NOTICE

Ferrous metal within a 100 mm [3.9 in] radius of the magnet may affect sensor performance.

100° and 180° Arc Configurations

Figure 1. Dimensional Drawings (For reference only: mm)

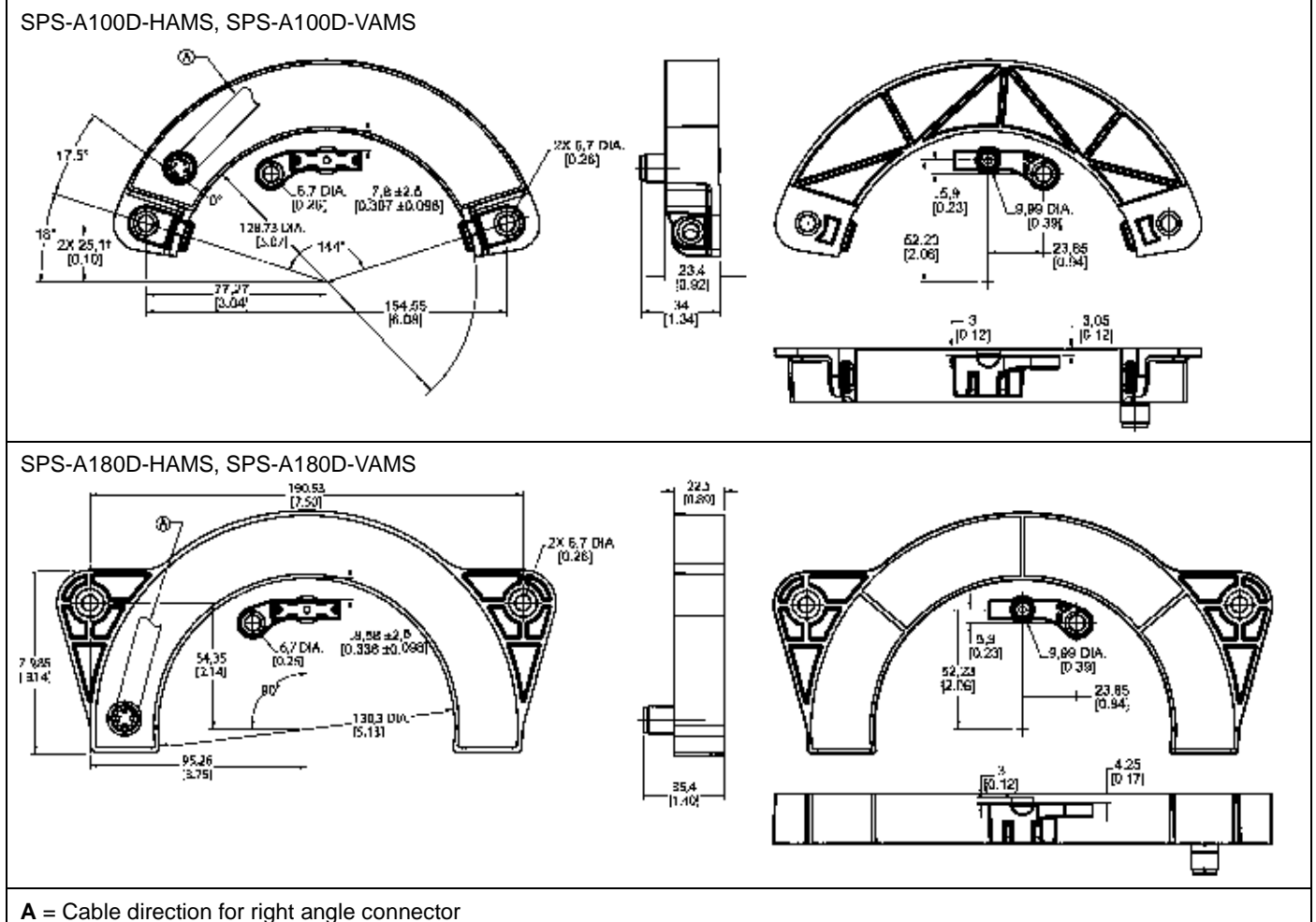
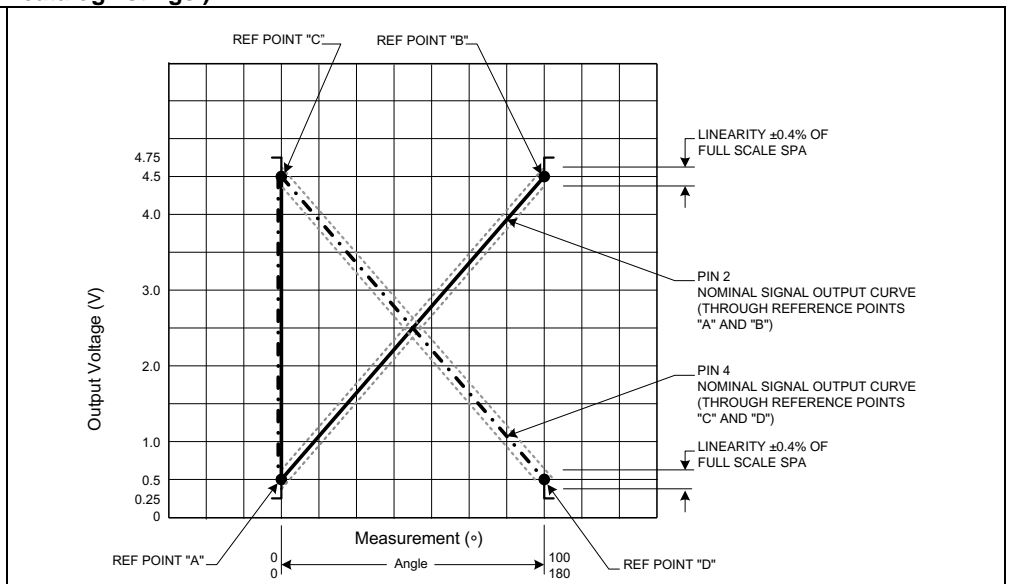
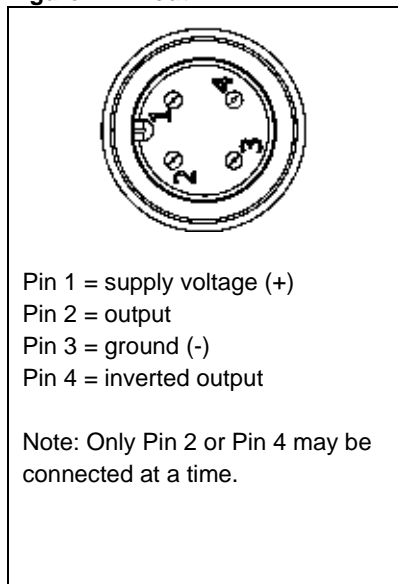

Figure 3. Sensor Output Performance Chart Showing Ideal Outputs (Applies to all catalog listings.)

Figure 2. Pinout



Order Guide

Catalog Listing	Description
SPS-A100D-HAMS	SMART Position Sensor, 100° arc configuration, 0° to 100° sensing range, 6 Vdc to 24 Vdc supply voltage, 0.5 Vdc to 4.5 Vdc analog output, magnet actuator included
SPS-A100D-VAMS	SMART Position Sensor, 100° arc configuration, 0° to 100° sensing range, 18 Vdc to 40 Vdc supply voltage, 0.5 Vdc to 4.5 Vdc, analog output, magnet actuator included
SPS-A180D-HAMS	SMART Position Sensor, 180° arc configuration, 0° to 180° sensing range, 6 Vdc to 24 Vdc supply voltage, 0.5 Vdc to 4.5 Vdc, analog output, magnet actuator included
SPS-A180D-VAMS	SMART Position Sensor, 180° arc configuration, 0° to 180° sensing range, 18 Vdc to 40 Vdc supply voltage, 0.5 Vdc to 4.5 Vdc, analog output, magnet actuator included

WARNING

PERSONAL INJURY

DO NOT USE these products as safety or emergency stop devices or in any other application where failure of the product could result in personal injury.

Failure to comply with these instructions could result in death or serious injury.

WARRANTY/REMEDY

Honeywell warrants goods of its manufacture as being free of defective materials and faulty workmanship. Honeywell's standard product warranty applies unless agreed to otherwise by Honeywell in writing; please refer to your order acknowledgement or consult your local sales office for specific warranty details. If warranted goods are returned to Honeywell during the period of coverage, Honeywell will repair or replace, at its option, without charge those items it finds defective. **The foregoing is buyer's sole remedy and is in lieu of all other warranties, expressed or implied, including those of merchantability and fitness for a particular purpose. In no event shall Honeywell be liable for consequential, special, or indirect damages.**

While we provide application assistance personally, through our literature and the Honeywell web site, it is up to the customer to determine the suitability of the product in the application.

Specifications may change without notice. The information we supply is believed to be accurate and reliable as of this printing. However, we assume no responsibility for its use.

WARNING

MISUSE OF DOCUMENTATION

- The information presented in this product sheet is for reference only. Do not use this document as a product installation guide.
- Complete installation, operation, and maintenance information is provided in the instructions supplied with each product.

Failure to comply with these instructions could result in death or serious injury.

SALES AND SERVICE

Honeywell serves its customers through a worldwide network of sales offices, representatives and distributors. For application assistance, current specifications, pricing or name of the nearest Authorized Distributor, contact your local sales office or:

E-mail: info.sc@honeywell.com

Internet: www.honeywell.com/sensing

Phone and Fax:

Asia Pacific	+65 6355-2828 +65 6445-3033 Fax
Europe	+44 (0) 1698 481481 +44 (0) 1698 481676 Fax
Latin America	+1-305-805-8188 +1-305-883-8257 Fax
USA/Canada	+1-800-537-6945 +1-815-235-6847 +1-815-235-6545 Fax

Sensing and Control
Honeywell
1985 Douglas Drive North
Golden Valley, MN 55422
www.honeywell.com

000732-1-EN IL50 GLO Printed in USA
March 2011
Copyright © 2011 Honeywell International Inc. All rights reserved.

Honeywell