

## Model MAQ13

### Accelerometer



#### DESCRIPTION

The Model MAQ13 charge output miniature accelerometer is designed to be used in Industrial test and automation environments; including laboratory testing, modal studies and test cells where high temperatures are likely to be encountered and where space is limited and small size is desired or a high natural frequency is required. The MAQ13 is a self-generating piezoelectric transducer which has no internal electronics and requires no external power for operation. These units are usually connected to a local charge amplifier that is mounted as near as possible

in a lower temperature environment. The Model MAQ13 features a wide frequency range, and a flat sensitivity vs. temperature response over the temperature range. The seismic element is mechanically isolated from the mounting base, resulting in a low base strain sensitivity. The stainless steel materials are non-magnetic resulting in very low magnetic field susceptibility. These features, together with a sealed body, assure accurate and reliable data.

#### FEATURES

- Small size
- Charge output (pC/G)
- 30 kHz mounted frequency
- General purpose
- Suitable for high temperatures
- Side entry microdot connector
- No internal electronics

# Model MAQ13

## PERFORMANCE SPECIFICATIONS

Characteristic	Measure
Dynamic range	±800 G
Sensitivity	20 pC/G std.
Transverse sensitivity	Less than 5 %
Temperature sensitivity	0.145/°F
Frequency range	Dependent on charge amplifier
Amplitude linearity	Better than 1 % linearity
Mounted base resonance	30 kHz

## ENVIRONMENTAL SPECIFICATIONS

Characteristic	Measure
Temperature, operating	-57 °C to 249 °C [-70 °F to 480 °F]
Sealing	IP67/NEMA 4

## ELECTRICAL SPECIFICATIONS

Characteristic	Measure
Input	Self generating
Output	Charge
Charge amplitude required	CA2
Mating connector	Microdot
Capacitance	450 pF
Isolation	Base isolated

## MECHANICAL SPECIFICATIONS

Characteristic	Measure
Weight	0,03 kg [1 oz]
Material	Stainless steel
Mounting torque	2 ft-lb

## SENSITIVITY CODES

Sensitivity Code	Sensitivity
YC	10 pC/G
YD	20 pC/G
YE	30 pC/G

## WIRING CODES

Wire	
Center	(+) Output
Shield	Case ground

## OPTION CODES

	Many range/option combinations are available in our quick-ship and fast-track manufacture programs. Please see <a href="http://sensing.honeywell.com/TMsensor-ship">http://sensing.honeywell.com/TMsensor-ship</a> for updated listings.
Sensitivity	10 pC/G, 20 pC/G, 30 pC/G

## MOUNTING DIMENSIONS

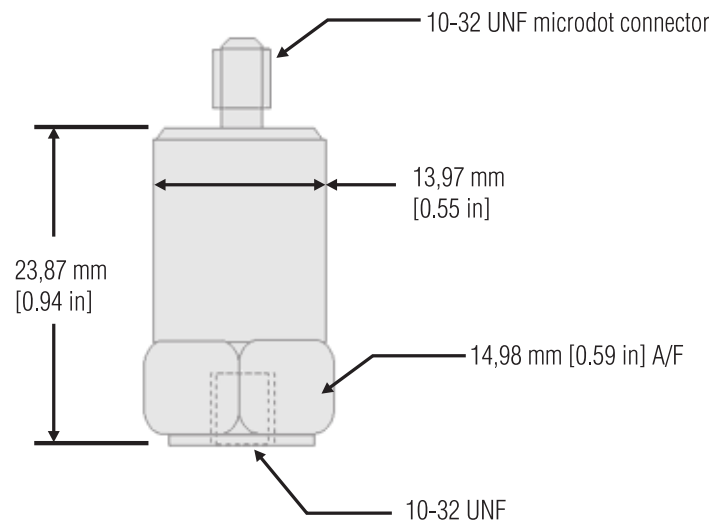

## TYPICAL SYSTEM DIAGRAM

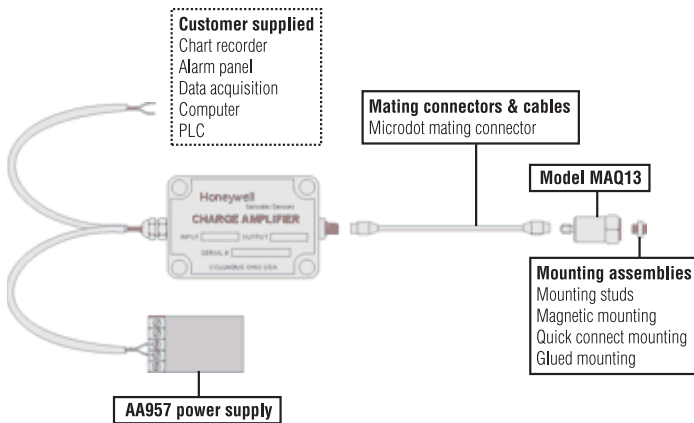

**Warranty.** Honeywell warrants goods of its manufacture as being free of defective materials and faulty workmanship. Honeywell's standard product warranty applies unless agreed to otherwise by Honeywell in writing; please refer to your order acknowledgement or consult your local sales office for specific warranty details. If warranted goods are returned to Honeywell during the period of coverage, Honeywell will repair or replace, at its option, without charge those items it finds defective. **The foregoing is buyer's sole remedy and is in lieu of all warranties, expressed or implied, including those of merchantability and fitness for a particular purpose. In no event shall Honeywell be liable for consequential, special, or indirect damages.**

While we provide application assistance personally, through our literature and the Honeywell web site, it is up to the customer to determine the suitability of the product in the application.

Specifications may change without notice. The information we supply is believed to be accurate and reliable as of this printing. However, we assume no responsibility for its use.

For more information about Sensing and Control products, visit [www.honeywell.com/sensing](http://www.honeywell.com/sensing) or call +1-815-235-6847  
Email inquiries to [info.sc@honeywell.com](mailto:info.sc@honeywell.com)

### **⚠ WARNING** **PERSONAL INJURY**

- DO NOT USE these products as safety or emergency stop devices or in any other application where failure of the product could result in personal injury.

**Failure to comply with these instructions could result in death or serious injury.**

### **⚠ WARNING** **MISUSE OF DOCUMENTATION**

- The information presented in this catalogue is for reference only. DO NOT USE this document as product installation information.
- Complete installation, operation and maintenance information is provided in the instructions supplied with each product.

**Failure to comply with these instructions could result in death or serious injury.**