

Model JTF

General Purpose Accelerometer



DESCRIPTION

The JTF accelerometers offer three mounting choices to meet specific application requirements. The sensing technique for these accelerometers is based on piezoresistive technology. Frequency response extends down to dc. Hermetic construction of the JTF Series provides dependable performance in harsh industrial environments. The case material is non-magnetic from

either anodized aluminum or stainless steel which provides low magnetic field susceptibility. Our standard in-line amplifiers and Instrumentation may be used with the JTF Series accelerometers. The screw mount model can be supplied with an optional triaxial mounting block, allowing for more than one accelerometer to be used.

FEATURES

- 0 Hz operation
- Easy calibration
- Low impedance
- Screw, bolt, or stud mounting options
- mV/G output
- Can run at 0 Hz
- Low magnetic field due to case material

Model JTF

PERFORMANCE SPECIFICATIONS

Characteristic	Measure
Dynamic range	±5 G to 200 G (peak G)
Sensitivity	See range code table
Transverse sensitivity	Less than 5 %
Frequency range	See range code table
Frequency response ¹	±5 %
Non-linearity and hysteresis	±1 % full scale
Mounted base resonance	See range code table
Damping ratio (nominal)	0.7 C @ 21 °C [70 °F]

ENVIRONMENTAL SPECIFICATIONS

Characteristic	Measure
Temperature, operating	-40 °C to 121 °C [-40 °F to 250 °F]
Temperature, compensated	21 °C to 93 °C [70 °F to 200 °F] ¹
Temperature effect, zero (max.)	0.02 % full scale/ °F
Temperature effect, sensitivity (max.)	±10 %

ELECTRICAL SPECIFICATIONS

Characteristic	Measure
Excitation, calibration	5 Vdc
Excitation, acceptable	Up to 10 Vdc
Electrical termination, AG111	Teflon cable 1,5 m [5 ft]
Electrical termination, AG112/AG113	10-32 UNF 4-pin connector
Mating connector	10-32 UNF socket plug ²

RANGE CODES

Range code	Available ranges (peak G)	Sensitivity nominal	Sensitivity range	Usable frequency range	Mounted resonant frequency
GJ	±5 G	8 mV/G	5 mV/G to 12 mV/G	0 Hz to 300 Hz	800 Hz
GK	±10 G	3.8 mV/G	2.4 mV/G to 5 mV/G	0 Hz to 400 Hz	1000 Hz
GL	±20 G	1.8 mV/G	1.2 mV/G to 2.4 mV/G	0 Hz to 600 Hz	1500 Hz
GN	±50 G	0.8 mV/G	0.5 mV/G to 1.2 mV/G	0 Hz to 1000 Hz	2000 Hz
GP	±100 G	0.38 mV/G	0.24 mV/G to 0.5 mV/G	0 Hz to 1500 Hz	3000 Hz
GV	±200 G	0.18 mV/G	0.12 mV/G to 0.24 mV/G	0 Hz to 2000 Hz	4000 Hz

MECHANICAL SPECIFICATIONS

Characteristic	Measure
Acceleration limits (any direction)	x20
Weight, AG111	0,03 kg [1 oz]
Weight, AG112 & AG113	0,06 kg [2.1 oz]
Case material, AG111	Anodized Aluminum
Case material, AG112 and AG113	Stainless steel

OPTION CODES

AG111	Many range/option combinations are available in our quick-ship and fast-track manufacture programs. Please see http://sensing.honeywell.com/TMsensor-ship for updated listings.
Range	5 G, 10 G, 20 G, 50 G, 100 G, 200 G

WIRING CODES

Screw mount	
Red	(+) Excitation
Black	(-) Excitation
Green	(-) Output
White	(+) Output

Model JTF

General Purpose Accelerometer

NOTES

1. Output voltage is proportional to input voltage.
2. Only available with AG112 and AG113.

BOLT OR STUD MOUNT

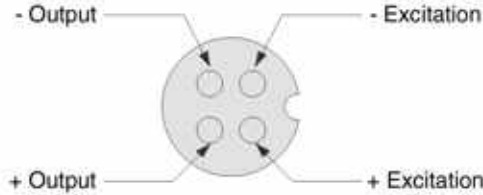

MOUNTING DIMENSIONS

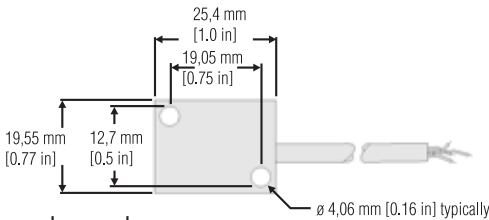

Model JTF screw mount (order code AG111)

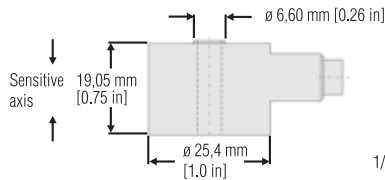

Model JTF bolt mount (order code AG112)

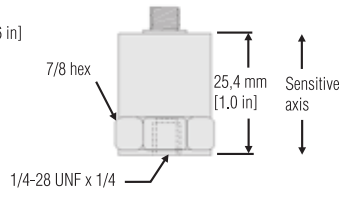

Model JTF stud mount (order code AG113)

TYPICAL SYSTEM DIAGRAM

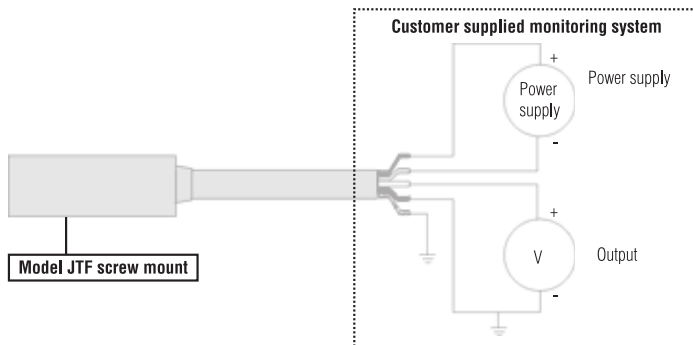

Warranty. Honeywell warrants goods of its manufacture as being free of defective materials and faulty workmanship. Honeywell's standard product warranty applies unless agreed to otherwise by Honeywell in writing; please refer to your order acknowledgement or consult your local sales office for specific warranty details. If warranted goods are returned to Honeywell during the period of coverage, Honeywell will repair or replace, at its option, without charge those items it finds defective. **The foregoing is buyer's sole remedy and is in lieu of all warranties, expressed or implied, including those of merchantability and fitness for a particular purpose. In no event shall Honeywell be liable for consequential, special, or indirect damages.**

While we provide application assistance personally, through our literature and the Honeywell web site, it is up to the customer to determine the suitability of the product in the application.

Specifications may change without notice. The information we supply is believed to be accurate and reliable as of this printing. However, we assume no responsibility for its use.

For more information about Sensing and Control products, visit www.honeywell.com/sensing or call +1-815-235-6847. Email inquiries to info.sc@honeywell.com

WARNING PERSONAL INJURY

- DO NOT USE these products as safety or emergency stop devices or in any other application where failure of the product could result in personal injury.

Failure to comply with these instructions could result in death or serious injury.

WARNING MISUSE OF DOCUMENTATION

- The information presented in this catalogue is for reference only. DO NOT USE this document as product installation information.
- Complete installation, operation and maintenance information is provided in the instructions supplied with each product.

Failure to comply with these instructions could result in death or serious injury.