

Model JEC DC-DC



Long Stroke Displacement Transducer

DESCRIPTION

Models JEC (free unguided armature) dc-dc long stroke displacement transducers utilize an improved internal circuit which incorporates both reverse polarity protection and voltage regulation. These features eliminate the danger of permanent damage if supply voltage is accidentally reversed, and ensure

that sensitivity will remain constant over large variations in supply voltage. These models require no further conditioning, thus permitting easy operation.

FEATURES

- Stainless steel construction
- Enhanced life cycle
- Voltage regulation
- Single or dual supply wiring (field selectable)
- Reverse polarity protected
- Not RoHS compliant

Model JEC DC-DC

PERFORMANCE SPECIFICATIONS

Characteristic	Measure
Stroke range	±12,7 mm to 203,2 mm [±0.5 in to 8.0 in]
Non-linearity (max.)	±0.25 % full scale
Output load (min.)	2000 ohm with three-wire supply, 20000 ohm with floating supply
Output impedance	2 ohm
Output sensitivity	±5 Vdc or 0 Vdc to 10 Vdc (field selectable)
Isolation	1000 V input to output
Polarity	Output is positive for outward stroke

ENVIRONMENTAL SPECIFICATIONS

Characteristic	Measure
Temperature, operating	-50 °C to 70 °C [-58 °F to 158 °F]
Temperature effect, zero (max.)	0.006 % full scale/°F
Temperature effect, span (max.)	0.017 % full scale/°F

ELECTRICAL SPECIFICATIONS

Characteristic	Measure
Element type	dc-dc displacement transducer
Power supply, single	24 Vdc to 40 Vdc @ 30 mA
Power supply, dual	±12 Vdc to ±20 Vdc @ 30 mA
Ripple power supply	30 mV peak to peak
Electrical termination	Multiconductor shielded cable (1.83 m [6 ft])
Reverse polarity protection	Yes

MECHANICAL SPECIFICATIONS

Characteristic	Measure
Case material	Stainless steel
Probe material	Stainless steel
Armature type	Free unguided
Probe thread	M5 x 0.8
Weight	See table
Spring force (max.)	Not applicable

RANGE CODES

Range Code	Available ranges
HP	±12,7 mm [±0.5 in]
HQ	±25,4 mm [±1.0 in]
HR	±50,8 mm [±2.0 in]
HS	±76,2 mm [±3.0 in]
HT	±101,6 mm [±4.0 in]
HU	±152,4 mm [±6.0 in]
HV	±203,2 mm [±8.0 in]

OPTION CODES

Range Code	Many range/option combinations are available in our quick-ship and fast-track manufacture programs. Please see http://sensing.honeywell.com/TMsensor-ship for updated listings.
Stroke ranges	±12,7 mm to 203,2 mm [±0.5 in to 8.0 in]
Electrical termination	Multiconductor shielded cable (1.83 m [6 ft]) TM405. Axial Bendix connector on body radial (side) TM406. Bendix connector on body
Electrical cable orientation	TM49. Axial cable exit
Mounting threads	TM511. 13/16-32 UNF
Improved linearity	L10. ±0.1 % max. linearity (less than or equal to ±101.6 mm [±4 in])

Long Stroke Displacement Transducer

MOUNTING DIMENSIONS

Range code	Available stroke range	L	X	Approx. body weight	Approx. armature weight
HP	±12,7 mm [±0.5 in]	175,26 mm [6.9 in]	43,18 mm [1.7 in]	212,62 g [7.5 oz]	28,35 g [1.0 oz]
HQ	±25,4 mm [±1.0 in]	203,2 mm [8.0 in]	68,58 mm [2.7 in]	269,32 g [9.5 oz]	56,70 g [2.0 oz]
HR	±50,8 mm [±2.0 in]	317,5 mm [12.5 in]	81,28 mm [3.2 in]	368,54 g [13.0 oz]	70,87 g [2.5 oz]
HS	±76,2 mm [±3.0 in]	429,26 mm [16.9 in]	119,38 mm [4.7 in]	496,12 g [17.5 oz]	85,05 g [3.0 oz]
HT	±101,6 mm [±4.0 in]	474,98 mm [18.7 in]	132,08 mm [5.2 in]	623,69 g [22.0 oz]	99,22 g [3.5 oz]
HU	±152,4 mm [±6.0 in]	665,48 mm [26.2 in]	182,88 mm [7.2 in]	850,49 g [30.0 oz]	113,40 g [4.0 oz]
HV	±203,2 mm [±8.0 in]	855,98 mm [33.7 in]	259,08 mm [10.2 in]	1247,37 g [44.0 oz]	141,75 g [5.0 oz]

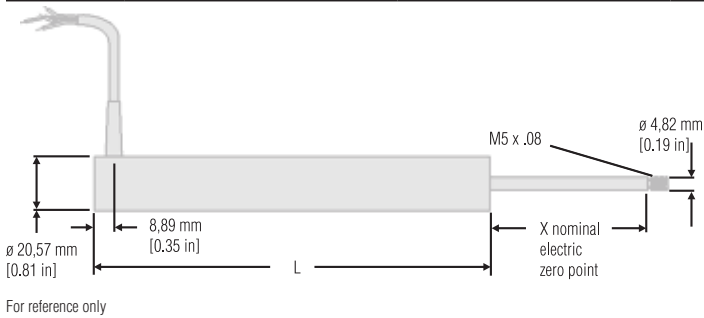

TYPICAL SYSTEM DIAGRAM

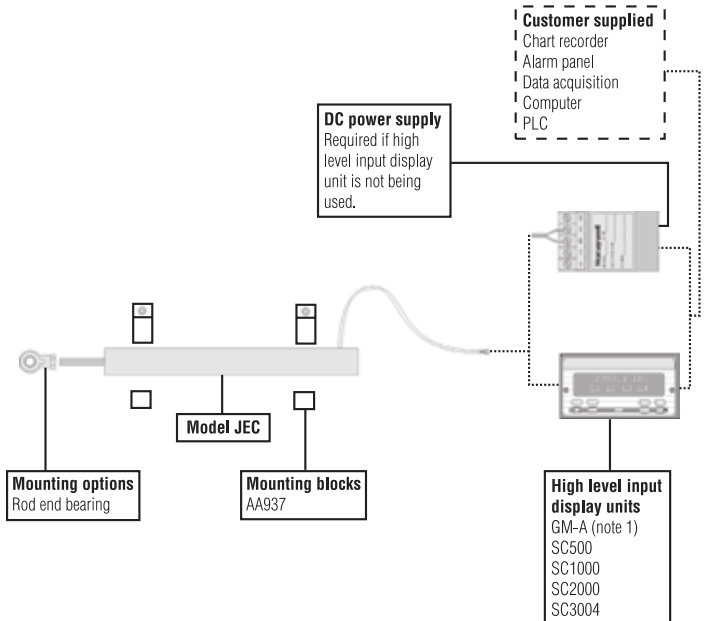

WIRING CODES

Wire color	Dual supply	Single supply (floating)*	Outputs
Red	12 V to 20 V input	24 V to 40 V input	
Blue	- 12 V to - 20 V input	Supply negative	
Black	O V, I/P, O/P common		
Yellow			0 V to 10 V
Green			±5 Vdc

* Output common floats at voltage source/2

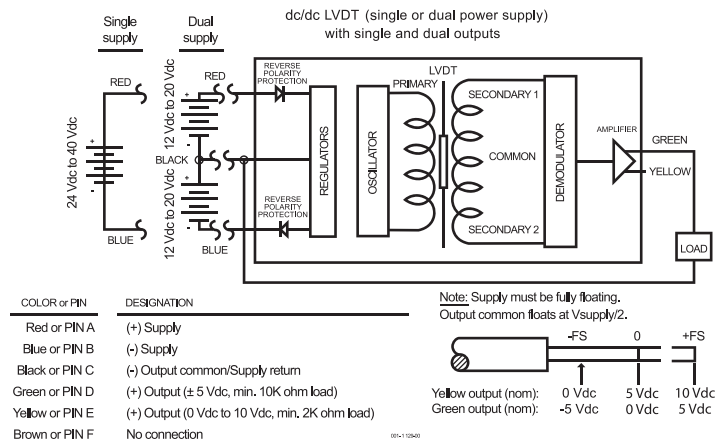

Model JEC DC-DC

Long Stroke Displacement Transducer

NOTES

1. GM-A should not be used with an amplified displacement transducer unless using an external power supply to power the displacement transducer.

Warranty. Honeywell warrants goods of its manufacture as being free of defective materials and faulty workmanship. Honeywell's standard product warranty applies unless agreed to otherwise by Honeywell in writing; please refer to your order acknowledgement or consult your local sales office for specific warranty details. If warranted goods are returned to Honeywell during the period of coverage, Honeywell will repair or replace, at its option, without charge those items it finds defective. **The foregoing is buyer's sole remedy and is in lieu of all warranties, expressed or implied, including those of merchantability and fitness for a particular purpose. In no event shall Honeywell be liable for consequential, special, or indirect damages.**

While we provide application assistance personally, through our literature and the Honeywell web site, it is up to the customer to determine the suitability of the product in the application.

Specifications may change without notice. The information we supply is believed to be accurate and reliable as of this printing. However, we assume no responsibility for its use.

For more information about Sensing and Control products, visit www.honeywell.com/sensing or call +1-815-235-6847

Email inquiries to info.sc@honeywell.com

WARNING **PERSONAL INJURY**

- DO NOT USE these products as safety or emergency stop devices or in any other application where failure of the product could result in personal injury.

Failure to comply with these instructions could result in death or serious injury.

WARNING **MISUSE OF DOCUMENTATION**

- The information presented in this catalogue is for reference only. DO NOT USE this document as product installation information.
- Complete installation, operation and maintenance information is provided in the instructions supplied with each product.

Failure to comply with these instructions could result in death or serious injury.

Sensing and Control
Automation and Control Solutions
Honeywell
1985 Douglas Drive North
Golden Valley, MN 55422 USA
+1-815-235-6847
www.honeywell.com/sensing

008763-1-EN IL50 GLO
May 2008
Copyright © 2008 Honeywell International Inc. All rights reserved.

Honeywell