

Model HL-A-5

High Line Wet/Wet Differential Pressure Transducer



DESCRIPTION

The High Line Wet/Wet Differential Pressure Model HL-A-5 is designed to accept extreme line pressures of up to 5000 psi.* This unique design features standard bonded foil strain gages on stainless steel. Liquid and gas differential pressures of 50 psid to 7500 psid are measured within a 0.50 % full scale accuracy.

A variety of standard options are available with the Model HL-A-5 including the traditional removable pressure adaptors for cleaning purposes, extended temperature ranges, alternative pressure ports, internal amplifiers options, and electrical terminations.

FEATURES

- 0.5 % accuracy
- Line pressure to 5000 psi
- mV/V (standard), 4 mA to 20 mA, 0 Vdc to 5 Vdc, or 0 Vdc to 10 Vdc output
- Intrinsically safe available (2N option only)¹⁰
- CE approved¹¹

Model HL-A-5

PERFORMANCE SPECIFICATIONS

Characteristic	Measure
Pressure ranges	50, 75, 100, 150, 200, 300, 500, 750, 1000, 1500, 2000, 3000, 5000, 7500* psid
Accuracy	±0.5 % full scale
Linearity	±0.25 % full scale (typical)
Hysteresis	±0.13 % full scale (typical)
Non-repeatability	±0.07 % full scale (typical)
Output (standard)	2 mV/V (nominal)
Line pressure	2500 psi**
Resolution	Infinite

ENVIRONMENTAL SPECIFICATIONS

Characteristic	Measure
Temperature, operating	-54 °C to 121 °C [-65 °F to 250 °F]
Temperature, compensated	15 °C to 71 °C [60 °F to 160 °F]
Temperature, effect, zero	±0.75 % full scale/100 °F
Temperature, effect, span	±1 % reading/100 °F

ELECTRICAL SPECIFICATIONS

Characteristic	Measure
Strain gage type	Bonded foil
Excitation (calibration)	10 Vdc
Bridge resistance	350 ohm
Shunt calibration data	Included
Elec. termination (std)	PTIH-10-6P or equivalent (hermetic stainless)
Mating connector (not incl.)	PT06A-10-6S or equiv. (AA111)

MECHANICAL SPECIFICATIONS

Characteristic	Measure
Media	Gas, liquid
Overload-safe	
50 psid to 1500 psid	2000 psi
2000 psid to 7500 psid	Full scale capacity + 2000 psi
Pressure port	1/4-18 NPT female
Wetted parts material	17-4 PH stainless steel
Case material	Stainless steel

OPTION CODES

	Many range/option combinations are available in our quick-ship and fast-track manufacture programs. Please see http://measurementsensors.honeywell.com for updated listings.	
Pressure ranges (psid)	50, 75, 100, 150, 200, 300, 500, 750, 1000, 1500, 3000, 5000, 7500	
Temperature compensation	1a. 60 °F to 160 °F 1b. 30 °F to 130 °F 1c. 0 °F to 185 °F 1d. -20 °F to 130 °F 1e. -20 °F to 200 °F	1f. 70 °F to 250 °F 1i. -65 °F to 250 °F ⁶ 1j. 0 °C to 50 °C 1m. -25 °C to 110 °C
Internal amplifiers	2u. Unamplified, mV/V output 2b. 4 wire ±5 Vdc 2c. 0 Vdc to 5 Vdc 2t. 0 Vdc to 10 Vdc 2j. 4 mA to 20 mA (three wire) output	2k. 4 mA to 20 mA (two wire) output ¹² 2n. (2N) 4 mA to 20 mA (two wire) intrinsically safe ¹²
Internal amp enhancements	3a. Input/output isolation ⁸ 3d. Remote buffered shunt calibration	
Pressure ports ⁵	5a. 1/4-18 NPT female 5c. 7/16-20 UNF female (per MS33656E4)	
Electrical termination	6a. Bendix PTIH-10-6P (or equiv.) 6 pin (max. 250 °F) 6b. MS type connector to mate with MS3106-14S-6S (max. 160 °F) ¹ 6e. Integral cable: Teflon (-54 °C to 245 °C) 6f. Integral cable: PVC (-30 °C to 70 °C)	6g. Integral cable: Neoprene (-20 °C to 80 °C) ¹ 6h. Integral cable: Silicone (-54 °C to 150 °C) 6i. Integral underwater cable (8m [26 ft]) (max. 80°C) ¹ 6j. 1/2-14 conduit fitting with 1,5 m [5 ft] of 4 conductor PVC cable
Shunt calibration	8a. Precision internal resistor ⁶	
Special calibration	9a. 10 point (5 up/5 down) 20% increments @ 20 °C 9b. 20 point (10 up/10 down) 10% increments @ 20 °C	
Wetted diaphragm	17-4 PH stainless steel	
Bridge type	11a. Square bridge ⁶ 11b. Symmetrical bridge ⁶ 11c. Square & symmetrical bridge ⁶	
Zero and span adjustment	14b. Top access to pots ⁷ 14a. No access to pots	
Increased line pressure	25b. 3000 psi line pressure 25c. 5000 psi line pressure	
Interfaces	53e. Signature calibration ⁶ 53t. TEDS IEEE 1451.4 module ⁹	

High Line Wet/Wet Differential Pressure Transducer

INTERNAL AMPLIFIERS

	Voltage output: Option 2b	Voltage output: Option 2c	Voltage output: Option 2t	Current three-wire: Option 2j	Current two-wire: Option 2k	Intrinsically safe amp: Option 2n (2N)***
Output signal	±5 V	0 V to 5 V or ±5 V @ 5 mA	0 V to 10 V or ±10 V @ 5 mA	4 mA to 20 mA	4 mA to 20 mA	4 mA to 20 mA
Input power (voltage)	±15 V or 26 Vdc to 32 Vdc	11 Vdc to 28 Vdc	15 Vdc to 28 Vdc	22 Vdc to 32 Vdc	9 Vdc to 32 Vdc	9 Vdc to 28 Vdc
Input power (current)	45 mA	40 mA	40 mA	65 mA	4 mA to 28 mA	4 mA to 24 mA
Freq. resp (amp)	3000 Hz	3000 Hz	3000 Hz	2500 Hz	300 Hz	2000 Hz
Power supply rej.	60 db	60 db	60 db	60 db	60 db	60 db
Operating temp.	-20 °F to 185 °F	-20 °F to 185 °F	-20 °F to 185 °F	0 °F to 185 °F	0 °F to 185 °F	-20 °F to 185 °F
Reverse voltage protection	Yes	Yes	Yes	Yes	Yes	Yes
Short cir. protection	Momentary	Momentary	Momentary	Yes	Yes	Yes
Wiring code: connector(std)²	A (+) Supply B Output common C Supply return D (+) Output E Shunt cal 1 F Shunt cal 2	A (+) Supply B Output common** C Supply return ** D (+) Output E Shunt cal 1 F Shunt cal 2	A (+) Supply B Output common** C Supply return** D (+) Output E Shunt cal 1 F Shunt cal 2	A (+) Supply B Output common** C Supply return** D (+) Output E Shunt cal 1 F Shunt cal 2	A (+) Supply B No connection C No connection D (+) Output E Case ground F No connection	A (+) Supply B No connection C No connection D (+) Output E Case ground F No connection
Wiring code: cable^{2,3,4}	R (+) Supply Bl Output common G Supply return W (+) Output B Shunt cal 1 Br Shunt cal 2	R (+) Supply Bl Output common* G Supply return* W (+) Output B Shunt cal 1 Br Shunt cal 2	R (+) Supply Bl Output common* G Supply return* W (+) Output B Shunt cal 1 Br Shunt cal 2	R (+) Supply Bl Output common* G Supply return* W (+) Output B Shunt cal 1 Br Shunt cal 2	R (+) Supply Bl (+) Output W Case ground	R (+) Supply Bl (+) Output W Case ground

* Black and green wires are internally connected.

** Pins B and C are internally connected.

*** See Honeywell's Web site (<http://measurementsensors.honeywell.com>) for the most up-to-date information regarding Intrinsically safe approvals, ref #008-0547-00.

MOUNTING DIMENSIONS AND CHARACTERISTICS

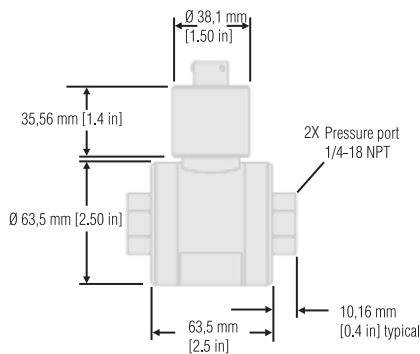

TYPICAL SYSTEM DIAGRAM

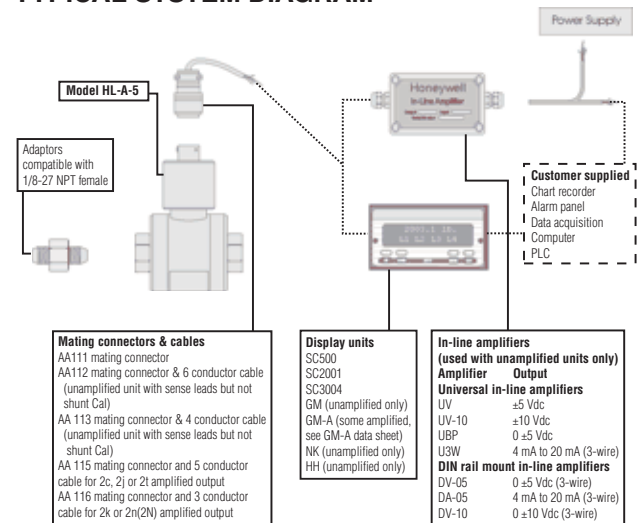

Model HL-A-5

RANGE CODES

Range Code	Available ranges	Range Code	Available ranges
BN	±50 psid	CT	±750 psid
BP	±75 psid	CV	±1000 psid
BR	±100 psid	DJ	±1500 psid
CJ	±150 psid	DL	±2000 psid
CL	±200 psid	DN	±3000 psid
CP	±300 psid	DR	±5000 psid
CR	±500 psid	DT	±7500 psid

WIRING CODES

Connector	Unamplified
A, B	(+) excitation
C, D	(-) excitation
E	(-) output
F	(+) output

NOTES

1. Availability varies according to range.
2. Interconnecting shunt cal. 1 terminal with shunt cal. 2 terminal provides 50% (unamplified units), 75% (4 mA to 20 mA 3-wire units) or 80% (voltage amplified units of full scale output for quick calibration. Shunt calibration comes standard with internal amplifier options 2b, 2c, 2t and 2j.)
3. O=Orange, Y=Yellow, B=Blue, Bl=Black, R=Red, Br=Brown, W=White, G=Green. Color specifying cable and number or letter specifying connector.
4. No mating connector necessary for cable option.
5. Some pressure port options may require axial orientation.
6. Only available with unamplified option 2u.
7. Only available with amplified options.
8. Only available with Vdc output options 2b, 2c.
9. Consult factory for TEDS availability with amplified models.
10. Range dependent; consult factory. Termination dependent; consult factory.
11. Internal amp and termination dependent; consult factory.

Note: Unless otherwise specified on order, amplified units with 4 mA to 20 mA output will provide 4 mA at 0 psid and 20 mA at positive full scale and the unit will not operate in the negative direction. An available alternative is to specify 4 mA at negative full scale and 20 mA at positive full scale. All amps add 2 in to amplifier housing.

** On units ≥ 200 psid the sum of full scale pressure must be ≤ 9500 psi, on units < 200 psid consult factory

Model HL-A-5

High Line Wet/Wet Differential Pressure Transducer

Warranty. Honeywell warrants goods of its manufacture as being free of defective materials and faulty workmanship. Honeywell's standard product warranty applies unless agreed to otherwise by Honeywell in writing; please refer to your order acknowledgement or consult your local sales office for specific warranty details. If warranted goods are returned to Honeywell during the period of coverage, Honeywell will repair or replace, at its option, without charge those items it finds defective. **The foregoing is buyer's sole remedy and is in lieu of all warranties, expressed or implied, including those of merchantability and fitness for a particular purpose. In no event shall Honeywell be liable for consequential, special, or indirect damages.**

While we provide application assistance personally, through our literature and the Honeywell web site, it is up to the customer to determine the suitability of the product in the application.

Specifications may change without notice. The information we supply is believed to be accurate and reliable as of this printing. However, we assume no responsibility for its use.

WARNING

PERSONAL INJURY

- DO NOT USE these products as safety or emergency stop devices or in any other application where failure of the product could result in personal injury.

Failure to comply with these instructions could result in death or serious injury.

WARNING

MISUSE OF DOCUMENTATION

- The information presented in this datasheet is for reference only. DO NOT USE this document as product installation information.
- Complete installation, operation and maintenance information is provided in the instructions supplied with each product.

Failure to comply with these instructions could result in death or serious injury.

Find out more

Honeywell serves its customers through a worldwide network of sales offices, representatives and distributors. For application assistance, current specifications, pricing or name of the nearest Authorized Distributor, contact your local sales office. To learn more about Honeywell's test and measurement products, call **+1-614-850-5000**, visit **<http://measurementsensors.honeywell.com>**, or e-mail inquiries to **info.tm@honeywell.com**

Sensing and Control

Honeywell

1985 Douglas Drive North

Golden Valley, MN 55422 USA

www.honeywell.com/sensing

008716-2-EN IL50 GLO
December 2011

Copyright © 2011 Honeywell International Inc. All rights reserved.

Honeywell