

NOTICE: This is a Sneak Peek of a new product that is scheduled to be introduced to general sales in 2012. This document contains preliminary specifications that are subject to change. To obtain a product sample, please contact Chris Gottlieb at +1 763-954-6311 or chris.gottlieb@honeywell.com.

Honeywell

6DF Series

6 Degree of Freedom Inertial Measurement Unit, 6-D Motion Variant

Durable. Accurate. Eases Integration.



DESCRIPTION

Honeywell's 6DF (degrees of freedom) Inertial Measurement Unit (IMU), 6-D Motion Variant, is designed to provide 6-dimensional motion sensing from a single device over six degrees of freedom by sensing motion in the forward/backward, up/down, left/right accelerations and inclination angles, combined with rotation rates about three perpendicular axes (pitch, yaw, roll).

Because the movements and the rotation along the three axes are independent of each other, such motion is said to have "six degrees of freedom" (see Figure 1 on page 3).

The 6DF IMU measures the motion of the equipment onto which it is attached and delivers the data to the equipment's control module using CAN communications protocol, allowing the operator to focus on other equipment functions, enabling more precise control than can be achieved by using only the human eye, and increasing safety, stability and productivity. The CAN baud rate and CAN 29 bit IDs are according to J1939.

The 6DF Series may potentially be used in numerous Transportation, Industrial and Aerospace/Military applications with harsh environments.

VALUE TO CUSTOMER

- ★ **Designed to Six Sigma standards:** Six Sigma standards provide the highest level of product quality, performance, and consistency. Six Sigma provides confidence that the IMU will perform to specification. Some competitive products may be produced to much lower Sigma tolerances, which may result in some products not performing to the specification in some conditions
- ★ **Industry-leading durability:**
 - Aluminum housing protects device from damage due to stones, dust, dirt, pressure washing, and humidity, allowing for use in harsh and outdoor environments
 - Corrosion-resistance minimizes susceptibility to deterioration often experienced in salt water environments
 - Compatible to chemicals such as diesel fuel, hydraulic oil, gas/ethylene glycol, brake fluids, urea, liquid lime, NPK fertilizer, ammonia hydroxide, and alkaline degreasers
- IP67 and IP69k ratings provide resistance to weather
- Wide operating temperature range withstands most thermal extremes, preventing package breakage
- EMI (electromagnetic interference) and EMC (electromagnetic compatibility) rating protects device from environmental radio frequencies
- Reduces replacement and downtime due to broken parts, temperature incompatibilities, EMC and EMI, and exposure to chemicals
- ★ **Industry-leading accuracy:** Provides highly accurate 6-dimensional rotation and acceleration outputs due to the IMU's industry-leading durable packaging, industry-leading stability, temperature compensation, software filtering and design, and automotive-grade Six Sigma testing requirements

6DF Series

★ Eases integration

- SAEJ1939 CAN 29 bit identifier communication output—the standard for the Transportation segment—allows more data to be transmitted than RS-485 output
- IP67 and IP69k ratings minimizes the customer having to design a weather resistant packaging around the IMU, allowing for a wide range of use in the application
- Wide voltage range (7 V to 32 V) minimizes the need for a voltage converter
- Deutsch connector, common in Transportation applications, simplifies the customer's supply chain and reduces design complexity
- Chemical compatibility minimizes the OEM having to expose the device to the substances

● **6-dimensional motion sensing:** Senses 3-D motion in the forward/backward, up/down, and left/right accelerations combined with rotation about three perpendicular axes (pitch, yaw, roll):

- Provides key equipment operating data for automated steering and control
- Frees the operator to focus on equipment functions
- Enables precise control which otherwise cannot be achieved with the human eye alone
- Increase accuracy
- Increases safety
- Increases stability
- Increases operator productivity

★ **Industry-leading voltage input flexibility (7 V to 32 V):**

- Allows customers with multiple product lines the ability to purchase only one catalog listing instead of multiple listings
- Allows the IMU to accommodate voltage fluctuation within the vehicle/device
- Provides reverse polarity protection in case the end customer accidentally reverses the red and black battery voltage wires

★ **Industry-leading application expertise:** Honeywell's application engineers are available to provide assistance to customers to help troubleshoot unforeseen communication protocol data, helping to optimize the customers' system performance; additionally, Honeywell's application engineers are available to answer design questions during the development, launch, and production of the customer's product

★ **Industry-leading customization:** For Transportation-applications with high volumes over 500 units per year, Honeywell will consider offering customers a choice of any CAN protocol, acceleration range up to ± 6 g, rotation rates up to ± 75 °/s, inclination angles up to ± 50 ° and a sensor update rate from 1 Hz to 100 Hz:

- Allows customers to customize the IMU so that it readily fits into existing vehicle protocol architecture
- Allows customers the ability to make custom protocol inclusions into the IMU quickly and easily
- Allows fast customer development turnaround with expert engineering support
- No customization for Aerospace and Military ITAR-applicable applications

★ **Automotive-grade qualified:** Certified to operate in automotive-grade environments due to:

- Temperature compensated to operate from -40 °C to 85 °C [-40 °F to 185 °F]
- Meets EMC (electromagnetic compatibility) and EMI (electromagnetic interference) requirements
- Meets ESD (electrostatic discharge) requirements
- Chemical compatibility (e.g., diesel, hydraulic oil, gas/ethylene glycol, brake fluid, urea, liquid lime, NPK fertilizer, ammonia hydroxide, and alkaline degreaser)

★ **Industry-leading temperature performance:** A temperature sensor is placed within each rotation rate sensor within the IMU:

- Provides a temperature value to the processing module where the data samples are filtered and compensated
- Allows the customer's system to perform over a wide temperature range

● **Long-term stability:** Even after long-term use and thermal extremes, these sensors offer customers enhanced long-term stability:

- Minimizes system calibration needs
- Maximizes system performance
- Helps support system uptime by eliminating the need to service or replace the sensor during its application life

FEATURES AND BENEFITS

- **Industry-standard CAN J1939:** Provides easy-to-integrate, cost-effective, high-integrity serial data communications bus for real-time control applications, allowing enhanced error detection
- **Test to mechanical shock, thermal shock, and random vibration:** Provides the customer with durability in tough environments

POTENTIAL APPLICATIONS

Transportation:

- Tractors
- Harvesters
- Loaders
- Graders
- Bulldozers
- Cranes (special restrictions apply: please contact Chris Gottlieb, Senior Global Product Marketing Manager at chris.gottlieb@honeywell.com)

Industrial:

- Motion/level control (mining conveyors)
- Robotics
- Shaker tables

Aerospace/Military:

- Ground vehicles
- UAVs (unmanned aerial vehicle)

6 Degree of Freedom Inertial Measurement Unit, 6-D Motion Variant

Figure 1. Six Degrees of Freedom

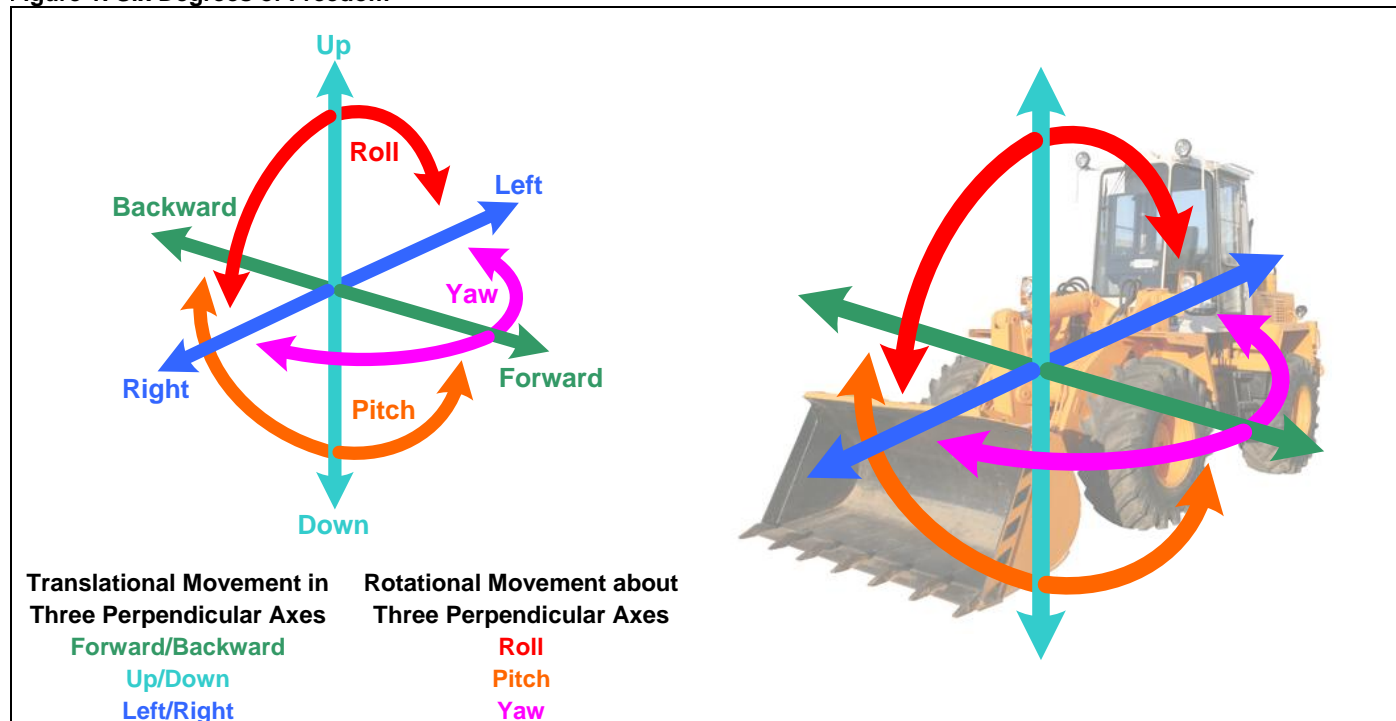

Table 1. General Specifications

Characteristic	Minimum	Typical	Maximum	Unit
Supply voltage	7	–	32	V
Supply current (at 12 V)	–	–	350	mA
Reverse voltage	–	–	-18	V
Startup time	–	700	2000	ms
Operating temperature	-40 [-40]	–	85 [185]	°C [°F]
Storage temperature	-40 [-40]	–	95 [203]	°C [°F]
Mechanical shock	–	–	30	g
Random vibration	3,2 g RMS max. (10 Hz to 2000 Hz), 3 orthogonal plane at 32 hr/axis			
Thermal shock	-40 °C to 105 °C [-40 °F to 221 °F] soak time, 30 min; transfer time less than 10 s, 30 cycles			
Humidity	95 %RH at 25 °C to 55 °C [77 °F to 131 °F]			
Salt spray	5% salt solution, 96 hr at 35 °C [95 °F]			
Chemical compatibility	diesel fuel, hydraulic oil, ethylene glycol, motor oil, brake fluid, urea nitrogen, liquid lime, NPK fertilizer, ammonia hydroxide, alkaline degreaser			
Sealing	IP67, IP69K ¹			
EMI/EMC: Emission Immunity	CISPR 25, ISO13766 ISO114252-2 (100 V/m at 200 MHz to 1 GHz, 50 V/m at 1 GHz to 2 GHz) ISO114252-5 (100 V/m at 10 kHz to 1 MHz) ISO114252-4 (100 mA at 1 MHz to 400 MHz)			
ESD	SAE J1113.13 (Nov 2004), 8 kV direct/15 kV air discharge			
Can bus standard	CAN-29 bits			

Note 1: Paint peel during IPX9K testing is not considered as failure.

6DF Series

Table 2. Installation Information

Characteristic	Description
Mating connector	Deutsch DT01-12S
Sealing plug	Deutsch 114017 (for unused connector terminations)
Weight	675 g
Heading direction	+X
Mounting direction	+Z
Mounting bolt	M6X1 socket head cap stainless steel, length 20 mm min., torque 8 N m to 10 N m

Table 3. Sensor Specifications

3-Axis Rotational Rate (X, Y, Z)							
Characteristic	6DF-1N2-C2-HWL and 6DF-1N6-C2-HWL			Unit			
	Minimum	Typical	Maximum				
Range	-75	-	75	°/s			
Resolution ¹	-	0.044	-	°/s			
Linearity error	-1	±0.25	1	°/s			
Noise	-	0.25	0.45	°/s (RMS)			
Sensitivity error	-4	±1.06	4	%FSS			
Offset error ²	-2.5	±0.5	2.5	°/s			
Frequency response	-	22	-	Hz			
G-Sensitivity ³	-0.8	±0.5	+0.8	°/s/g			
Noise (pk-pk) ⁴	-2	±1.5	2	°/s (pk-pk)			
2-Axis Inclination (X, Y)							
Characteristic	6DF-1N2-C2-HWL and 6DF-1N6-C2-HWL			Unit			
	Minimum	Typical	Maximum				
Range	-50	-	50	°			
Resolution ¹	-	0.025	-	°			
Linearity error	-0.2	±0.1	0.2	°			
Noise	-	0.2	0.45	° (RMS)			
Sensitivity error	-2	±1	2	%FSS			
Offset error ²	-2	±0.25	2	°			
Frequency response	-	30	-	Hz			
3-Axis Acceleration (X, Y, Z) ⁵							
Characteristic	6DF-1N2-C2-HWL			6DF-1N6-C2-HWL			Unit
	Minimum	Typical	Maximum	Minimum	Typical	Maximum	
Range	-19.81	-	19.81	-58.86	-	58.86	m/s ²
Resolution ¹	-	0.022	-	-	0.03	-	m/s ²
Linearity error	-0.392	±0.05	0.392	-0.687	±0.05	0.687	m/s ²
Noise	-	0.2	0.45	-	0.2	0.45	m/s ² (RMS)
Sensitivity error	-4	±0.5	4	-3	±0.5	3	%FSS
Offset error ²	-1	±0.245	1	-1	±0.490	1	m/s ²
Frequency response	-	24	-	-	24	-	Hz

Notes:

1. Resolution refers to sensor resolution and not CAN output resolution.
2. Offset error is measured at relatively zero level or on a flat surface.
3. G-Sensitivity is measured at 25 °C [77 °F].
4. Pk-pk noise of rotational rate sensor is measured at 0 °/s at 25 °C [77 °F].
5. Accelerometer specification is tested up to ±0.499 g (4.895 m/s²).

6 Degree of Freedom Inertial Measurement Unit, 6-D Motion Variant

Figure 2. Dimensional Drawing (For reference only: mm/[in])

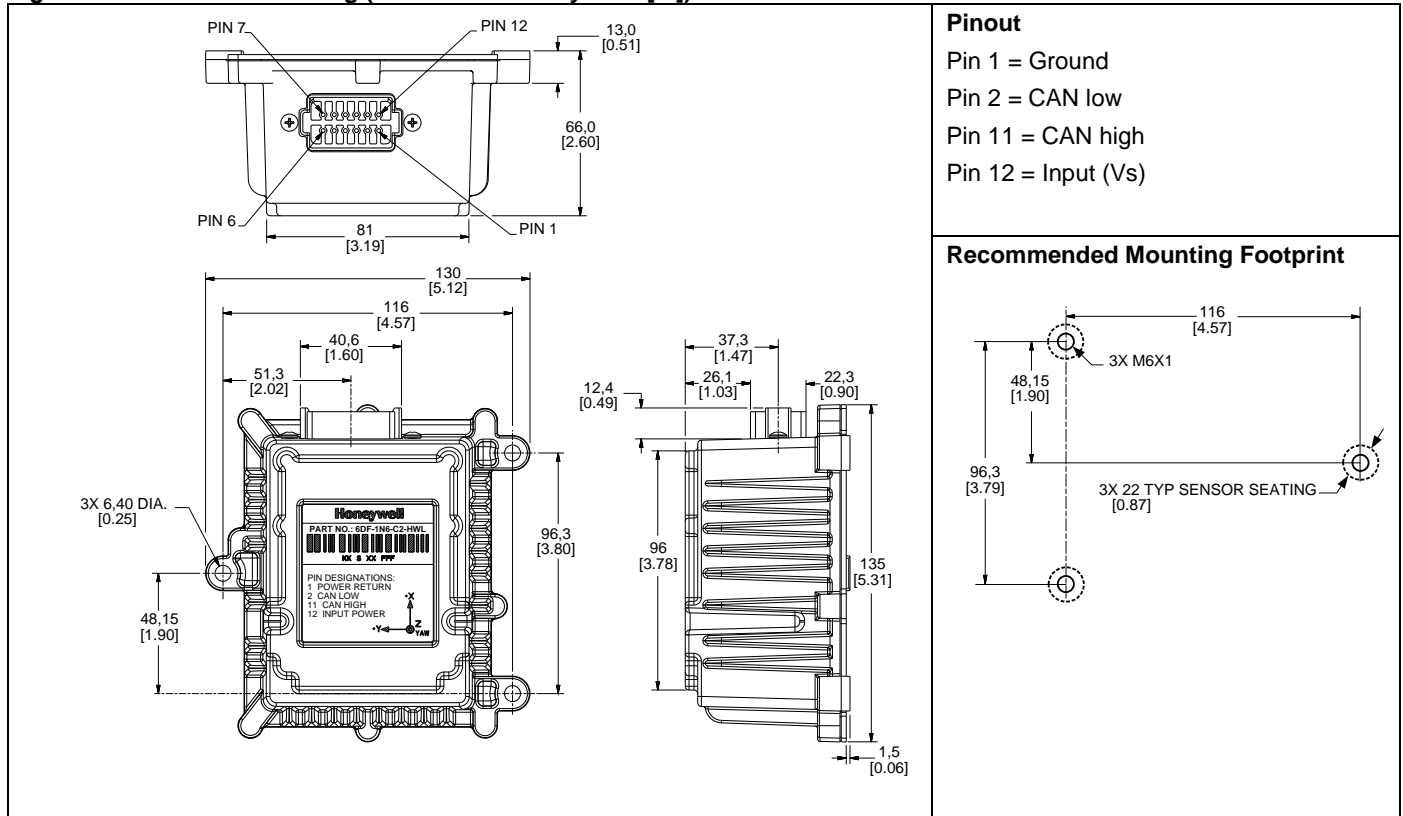
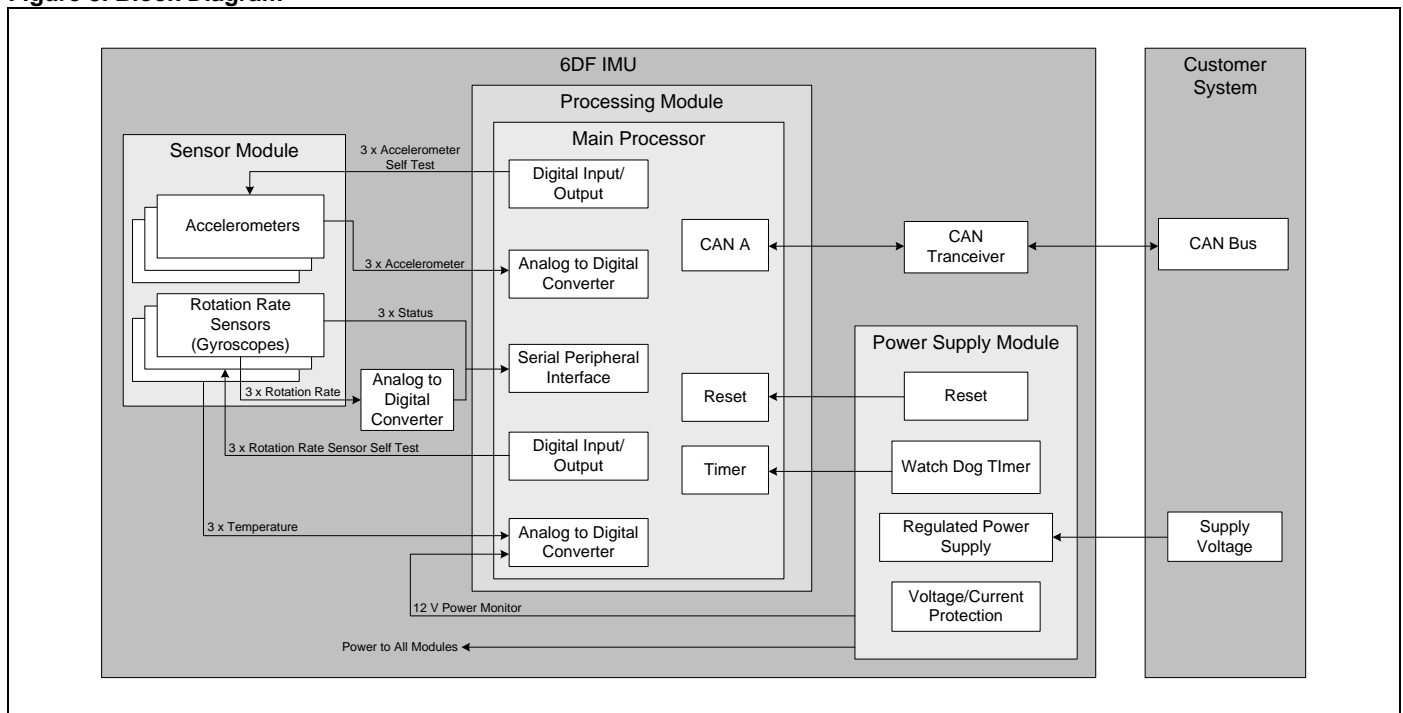

Figure 3. Block Diagram



6DF Series

CAN MESSAGES

Table 4. Messages Transmitted from the IMU to the Host in the Base Software Build

CAN Message	Message Identifier	Data Length	Description
Sensor data (lateral acceleration and yaw rate)	0xCFF955C	8 bytes	IMU to system
Sensor data (longitudinal acceleration and roll rate)	0xCFF965C	8 bytes	IMU to system
Sensor data (vertical acceleration and pitch rate)	0xCFF975C	8 bytes	IMU to system
Sensor data (roll angle and pitch angle)	0xCFF985C	8 bytes	IMU to system
Serial number, SW version no., HW version no.	0xCFF9E5C (remote frame)	8 bytes	IMU to system (on request)
Error status	0xCFF9F5C (remote frame)	8 bytes	IMU to system (on request)

Table 5. IMU to System (Yaw Rate and Lateral Acceleration Definition)

Message 0xCFF955C	Bits	Start Bit Position	Description
Rolling counter	8	0	increments the counter for every message sent; rolls from 255 to 0
Signal state for lateral acceleration	2	8	indicates if lateral acceleration data is valid
Signal state for yaw rate	2	10	indicates if yaw rate data is valid
Signal state for temperature	2	12	indicates if temperature data is valid
Vehicle dynamic lateral acceleration	16	16	digital filtered lateral acceleration signal
Vehicle dynamic yaw rate	16	32	digitally filtered yaw rate signal
Module temperature	8	48	module temperature
<Unused>	10	14-15, 56-63	–

Table 6. IMU to System (Roll Rate and Longitudinal Acceleration Definition)

Message 0xCFF965C	Bits	Start Bit Position	Description
Rolling counter	8	0	increments the counter for every message sent; rolls from 255 to 0
Signal state for longitudinal acceleration	2	8	indicates if longitudinal acceleration data is valid
Signal state for roll rate	2	10	indicates if roll rate data is valid
Vehicle dynamic longitudinal acceleration	16	16	digital filtered longitudinal acceleration signal
Vehicle dynamic roll rate	16	32	digitally filtered roll rate signal
Error information	16	48	error information
<Unused>	4	12-15	–

Table 7. IMU to System (Pitch Rate and Vertical Acceleration Definition)

Message 0xCFF975C	Bits	Start Bit Position	Description
Rolling counter	8	0	increments the counter for every message sent; rolls from 255 to 0
Signal state for vertical acceleration	2	8	indicates if vertical acceleration data is valid
Signal state for pitch rate	2	10	indicates if pitch rate data is valid
Vehicle dynamic vertical acceleration	16	16	digital filtered vertical acceleration signal
Vehicle dynamic pitch rate	16	32	digitally filtered pitch rate signal
<Unused>	20	12-15, 48-63	–

6 Degree of Freedom Inertial Measurement Unit, 6-D Motion Variant

Table 8. IMU to System (Roll and Pitch Inclination Angle Definition)

Message 0xCFF985C	Bits	Start Bit Position	Description
Rolling counter	8	0	increments the counter for every message sent; rolls from 255 to 0
Signal state for roll inclination angle	2	8	indicates if roll Inclination angle data is valid
Signal state for pitch inclination angle	2	10	indicates if pitch Inclination angle data is valid
Vehicle dynamic roll Inclination angle	16	16	digital filtered roll Inclination angle signal
Vehicle dynamic pitch Inclination angle	16	32	digitally filtered pitch Inclination angle signal
<Unused>	2	12-15, 48-63	-

Table 9. IMU to System (Serial Number Definition)¹

Message 0xCFF9E5C	Bits	Start Bit Position	Description
Module serial number	24	0	module serial number
Software version	8	24	software version
Production date	16	32	software release year, week
<Unused>	16	48-63	-

Note 1: This message can be requested by transmitting a message with ID 0xCFF9E5C and RTR bit set, to the IMU.

Table 10. IMU CAN Resolution

Number of bits	Numerical format	Resolution	Measurement Range	Value Range (hex)
Vehicle Dynamic Rates				
16	unsigned value	0.0078125 %/s	75	70xA57F
			0	0x7FFF
			-75	0x5A7F
Vehicle Dynamic Accelerations (6 g)				
16	unsigned value	0.01 m/s ²	58.86	0x96FD
			0	0x7FFF
			-58.86	0x6901
Vehicle Dynamic Accelerations (2 g)				
16	unsigned value	0.01 m/s ²	19.62	0x87A9
			0	0x7FFF
			-19.62	0x7855
Inclination Angles				
16	unsigned value	0.002 °	50	0xE1A7
			0	0x7FFF
			-50	0x1E57

Table 11. IMU System (Error Information – ID 0xCFF965C)

Number of Bits	Start Bit Position	Position Error Description
12	48	reserved
1	60	software error
1	61	SPI
1	62	ADC
1	63	IIC

Order Guide

Catalog Listing	Description
6DF-1N2-C2-HWL	6DF Series Inertial Measurement Unit, 6-D Motion Variant, 2 g accelerometer
6DF-1N6-C2-HWL	6DF Series Inertial Measurement Unit, 6-D Motion Variant, 6 g accelerometer

NOTICE

EVALUATION PRODUCTS

THESE PRODUCTS ARE PROTOTYPE, PREPRODUCTION ITEMS THAT HAVE YET TO COMPLETE ALL PHASES OF PRODUCT RELEASE TESTING AND ARE FOR CUSTOMER EVALUATION ONLY.

THESE ITEMS ARE SOLD "AS IS" WITH NO WARRANTY, EXPRESS OR IMPLIED, INCLUDING THAT OF MERCHANTABILITY AND FITNESS FOR A PARTICULAR PURPOSE.

IN NO EVENT WILL HONEYWELL BE LIABLE FOR ANY CONSEQUENTIAL, SPECIAL OR INDIRECT DAMAGES.

WARNING

PERSONAL INJURY

DO NOT USE these products as safety or emergency stop devices or in any other application where failure of the product could result in personal injury.

Failure to comply with these instructions could result in death or serious injury.

WARNING

MISUSE OF DOCUMENTATION

- The information presented in this product sheet is for reference only. Do not use this document as a product installation guide.
- Complete installation, operation, and maintenance information is provided in the instructions supplied with each product.

Failure to comply with these instructions could result in death or serious injury.

SALES AND SERVICE

Honeywell serves its customers through a worldwide network of sales offices, representatives and distributors. For application assistance, current specifications, pricing or name of the nearest Authorized Distributor, contact your local sales office or:

E-mail: info.sc@honeywell.com

Internet: www.honeywell.com/sensing

Phone and Fax:

Asia Pacific	+65 6355-2828; +65 6445-3033 Fax
Europe	+44 (0) 1698 481481; +44 (0) 1698 481676 Fax
Latin America	+1-305-805-8188; +1-305-883-8257 Fax
USA/Canada	+1-800-537-6945; +1-815-235-6847 +1-815-235-6545 Fax

P r e l i m i n a r y

This publication does not constitute a contract between Honeywell and its customers. The contents may be changed at any time without notice. It is the customer's responsibility to ensure safe installation and operation of the products. Detailed mounting drawings of all products illustrated are available upon request.

Sensing and Control
Honeywell
1985 Douglas Drive North
Golden Valley, Minnesota 55422
www.honeywell.com/sensing

Issue 1
April 2012
Copyright © 2012 Honeywell International Inc. All rights reserved.

Honeywell