

Figure 16. 3200 Series High Reliability Aerospace Thermostats

			
<p>The 3200 Series is a single-pole, single-throw switch activated by a snap-action bimetal disc. It is manufactured and tested to meet or exceed critical military and aerospace specifications for spaceflight use, including temperature stability, shock, vibration and cleanliness. The case is laser welded to form a hermetically-sealed steel housing, with a glass-to-metal seal at the terminal junction. Temperature calibrations are pre-set at the factory and each unit is thermally and mechanically inspected. It is available to open or close on temperature rise.</p> <p>The 3200EM (Engineering Model) version is produced using the same components as the 3200, but is not subjected to the rigors of extensive flight testing. It is specifically designed for ground and experimental testing.</p>	<table border="1" style="width: 100%; border-collapse: collapse;"> <tr> <td style="width: 50%; padding: 2px;"> A Contacts B Ceramic insulator C Ceramic pin guide D Disc retainer E Laser weld F Bimetal disc G Ceramic transfer pin </td> <td style="width: 50%; padding: 2px;"> H Cap I Contact arm J Backfill dry gas K Weld cap L Glass header M Terminals </td> </tr> </table> <p>Potential applications:</p> <ul style="list-style-type: none"> • Satellites • Rockets • Missiles 	A Contacts B Ceramic insulator C Ceramic pin guide D Disc retainer E Laser weld F Bimetal disc G Ceramic transfer pin	H Cap I Contact arm J Backfill dry gas K Weld cap L Glass header M Terminals
A Contacts B Ceramic insulator C Ceramic pin guide D Disc retainer E Laser weld F Bimetal disc G Ceramic transfer pin	H Cap I Contact arm J Backfill dry gas K Weld cap L Glass header M Terminals		

Table 41. 3200 Series Standard Temperature Characteristics

Temperature Setpoint Range	Tolerance		Nominal Differential °C [°F]
	Open °C [°F]	Close °C [°F]	
-51,1 °C to -29,4 °C [-60 °F to -21 °F]	consult factory		consult factory
-28,9 °C to 17,8 °C [-20 °F to 0 °F]	±4,4 [±8]	±3,9 [±7]	10,6 to 16,7 [19 to 30]
	±3,9 [±7]	±3,3 [±6]	9,4 to 15,0 [17 to 27]
	±3,3 [±6]	±3,3 [±6]	8,9 to 14,5 [16 to 26]
	±3,3 [±6]	±2,8 [±5]	8,3 to 13,9 [15 to 25]
	±2,8 [±5]	±2,8 [±5]	8,3 to 13,9 [15 to 25]
17,2 °C to 37,8 °C [1 °F to 100 °F]	±3,9 [±7]	±3,3 [±6]	9,4 to 15,0 [17 to 27]
	±3,3 [±6]	±3,3 [±6]	8,9 to 13,9 [16 to 25]
	±3,3 [±6]	±2,8 [±5]	8,3 to 13,9 [15 to 25]
	±2,8 [±5]	±2,8 [±5]	7,8 to 13,9 [14 to 25]
	±2,8 [±5]	±2,2 [±4]	7,2 to 13,9 [13 to 25]
	±2,2 [±4]	±2,2 [±4]	6,7 to 13,9 [12 to 25]
38,3 °C to 93,3 °C [101 °F to 200 °F]	±5,0 [±9]	±4,4 [±8]	11,7 to 16,7 [21 to 30]
	±3,9 [±7]	±3,3 [±6]	9,4 to 16,7 [17 to 30]
	±3,3 [±6]	±2,8 [±5]	8,3 to 16,75 [15 to 30]
	±2,8 [±5]	±2,8 [±5]	7,8 to 13,9 [14 to 25]
93,9 °C to 162,8 °C [200 °F to 325 °F]	±5,6 [±10]	±5,0 [±9]	12,8 to 19,4 [23 to 35]
	±4,4 [±8]	±3,3 [±6]	10,0 to 19,4 [18 to 35]
	±3,9 [±7]	±3,3 [±6]	9,4 to 19,4 [17 to 35]
	±3,3 [±6]	±3,3 [±6]	8,9 to 19,4 [16 to 35]

Table 42. 3200 Series Specifications

Characteristic	Parameter
Switch type	SPST
Reset type	automatic
Amperage	5 A resistive
Voltage	28 Vac/Vdc
Operating temperature range	-51 °C to 162,8 °C [-60 °F to 325 °F]
Environmental exposure range	-65 °C to 177 °C [-85 °F to 350 °F]
Dielectric strength	MIL-STD-202, Method 301, 1250 Vac
Insulation resistance	MIL-STD-202, Method 302, 500 MOhm
Contact resistance	MIL-STD-202, Method 307, 25 mOhm max.
Hermetic seal	MIL-STD-202, Method 112, Cond. C
Moisture resistance	MIL-STD-202, Method 106
Shock	MIL-STD-202, Method 213, 750 G
Vibration	MIL-STD-202, Method 204, 30 G, MIL-STD-202, Method 214, 50 G
Acceleration	MIL-STD-202, Method 212, 20 G
Thermal shock	MIL-STD-202, Method 107, Cond. B
Salt spray	MIL-STD-202, Method 101, Cond. B
Housing material	cold rolled plated steel
Marking	MIL-STD-1285
Approvals	NASA GSFC S-311-641, S-311-641/01
Weight	8,5 g [0.30 oz] (brackets and lead wires not included)

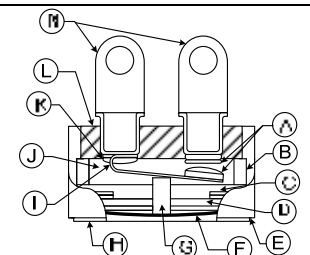
Table 43. 3200 Series Contact Ratings

Load Type	Life Cycles	28 Vac/dc	115 Vac
Resistive	100,000	5 A	2 A
Inductive	100,000	2.5 A	1 A
Lamp	100,000	1 A	0.5 A