

- Measuring range 0 – 500 m
- Accuracy +/- 1 mm
- For objects up to +1300 °C
- Up to +200 °C ambient temperature
- Parameterization with RS 485 + Software
- Analog output 4 – 20 mA
- 3 switching outputs (can be parameterized)
- Trigger input
- Cooling water connection
- Plug S8 (M12)
- G3/4" tread for protection hose connection



Product Characteristics

Type	LMB 100
Art.-No.	5200A
Application	distance measuring on hot objects, positioning in furnaces, hot rolling, pressing, forging, heat treatment

Technical Data

Measuring range	0 – 500 m* (can be parameterized)
Measurement accuracy max.	+/- 1 mm
Laser	Laser class 2
Trigger function	Single distance measuring at external trigger signal
Continuous measurement	Automatically distance measuring accuracy optimized
Quick continuous measurement	Automatically distance measuring speed optimized
Supply voltage	12 - 30 V DC
Ripple	max. 10 %
Current consumption	< 200 mA
Analog output	4 – 20 mA (12-Bit resolution)
Load impedance	100 – 500 Ω
Digital communication	RS 485 MODBUS RTU
Trigger input	12 – 30 V DC
Output	3x PNP normally open / normally closed (can be parameterized)
Continuous current	0 - 400 mA
Short-circuit protection	yes, pulsing
Voltage drop	< 2,5 V
Response time	10 ms – 1,5 s
Readiness delay	7 s
Ambient temperature	-10 ... +40 °C without cooling, up to 200 °C with cooling
Protection class	IP 67
Housing material	Stainless steel
Functional display	Duo-LED red/green
Status display	RGB-LED
Cooling water	~1l/min., 5 bar max.
Connection device	plug S8 (M12 x 1 A) 8 pole with G3/4" protective hose thread
Connection interface	plug S4 (M12 x 1 A) 5 pole
Weight	2,1 kg

* referred to a target plate Oralite 5200. At an object with reflectivity 80% measuring range max. 100 m. At an object with reflectivity 6% measuring range max. 65 m.

Connection

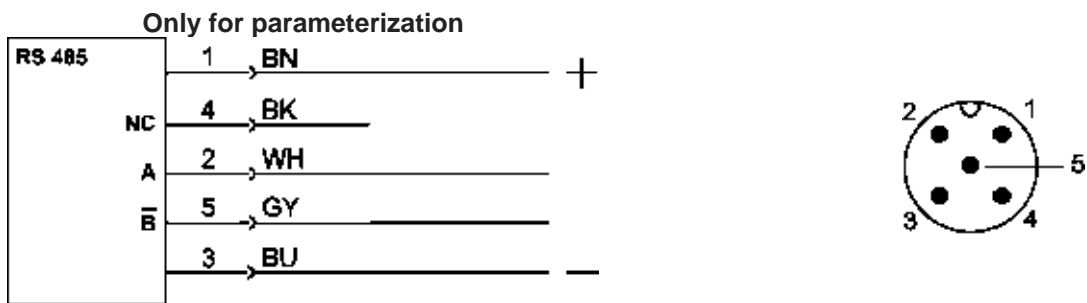
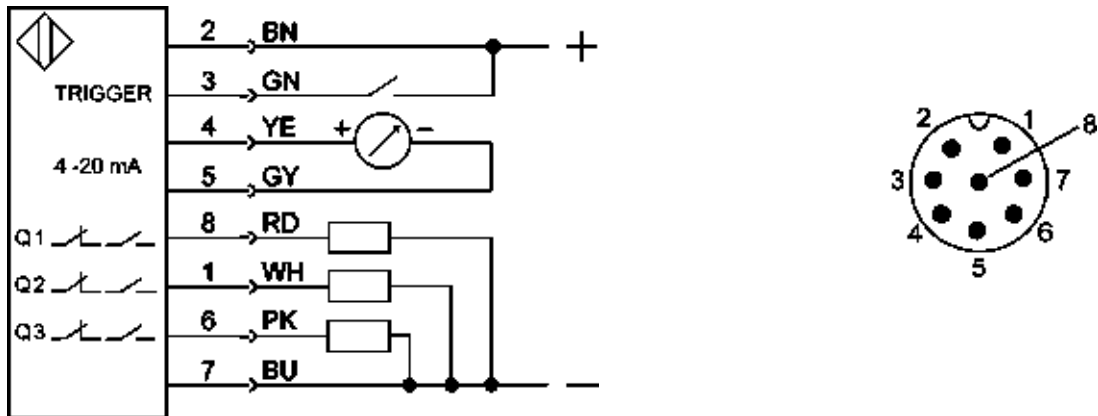

Dimension (mm)

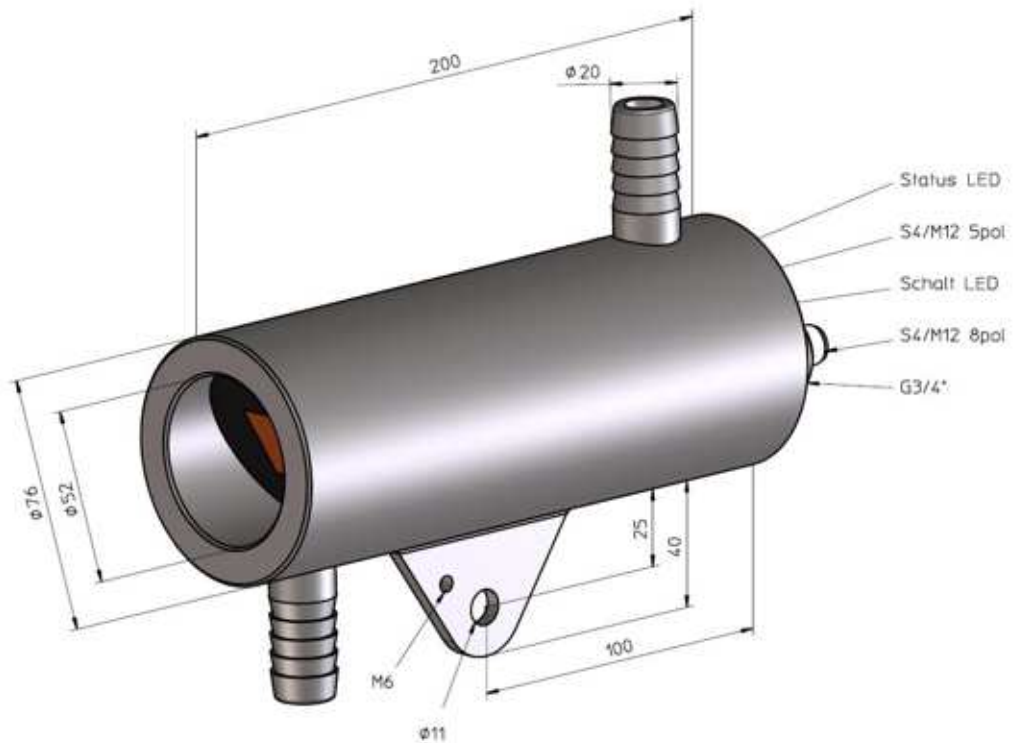

Accessories (not in scope of supply)

	Type	Art.-No.
Connection cable with female straight plug S8 (M12 x 1 A) 2 m PVC cable 8 x 0,25 mm ² up to 80 °C	ST S8-2	9850O
Connection cable with female straight plug S8 (M12 x 1 A) 5 m PCV cable 8 x 0,25 mm ² up to 80 °C	ST S8-5	9850N
Connection cable with female straight plug S8 (M12 x 1 A) 10 m PCV cable 8 x 0,25 mm ² up to 80 °C	ST S8-10	9850S
Connection cable with female straight plug S8 (M12 x 1 A) 5 m PUR cable 8 x 0,25 mm ² up to 90 °C	ST S8-5PUR	9844W
Connection cable with female straight plug S8 (M12 x 1 A) 5 m PTFE cable 8 x 0,25 mm ² up to 150 °C	ST S8-5PTFE	9844X
Swivel stand	HM 2	9816B
Adapter for protection hose connection (suitable protection hoses available)	HG 2	9855B
Tube	OL 21	9828C
Air purge attachment	OL 35	9828R
Tube for Air purge attachment	OL 36	9828S
Interface converter RS485, female plug S4 (M12 x 1 A) 5-pole to USB	SIC 485U	9861B
Power supply 90-260 VAC, 24 VDC / 1 A	PPS 2	9853B

Further Information

	Dokument
Manual	BDA_LMB100_D_E
Protection hoses	P46