

AMERICA'S FOOT SWITCH LEADER

Full Line Catalog

FULL SHIELD

CATALOG NUMBER: 534-Z24

- Cast Aluminum Alloy construction
- Resistant to impact
- Opening designed to easily accommodate most footwear
- Standard color is high visibility alert orange
- Special variations available in production quantities
- Entire foot switch is covered
- Accepts wide range of foot switch models

Size (HxWxD):	4.37 x 5.87 x 8.72 In.
Weight:	2.00 lb.

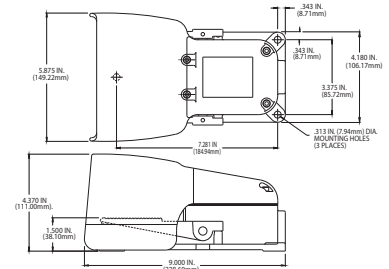

"O" SHIELD

CATALOG NUMBER: 534-A25

- Cast Aluminum Alloy construction
- Resistant to impact
- Opening designed to easily accommodate most footwear
- Standard color is high visibility alert orange
- Special variations available in production quantities
- Entire foot switch is covered
- Accepts wide range of foot switch models

Size (HxWxD):	5.03 x 6.03 x 8.72 In.
Weight:	2.25 lb.

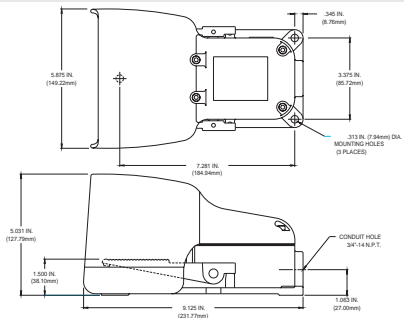

"OX" SHIELD

CATALOG NUMBER: 534-B25

- Cast Aluminum Alloy construction
- Resistant to impact
- Opening designed to easily accommodate most footwear
- Standard color is high visibility alert orange
- Special variations available in production quantities
- Entire foot switch is covered
- Accepts wide range of foot switch models

Size (HxWxD):	5.78 x 6.03 x 8.72 In.
Weight:	2.50 lb.

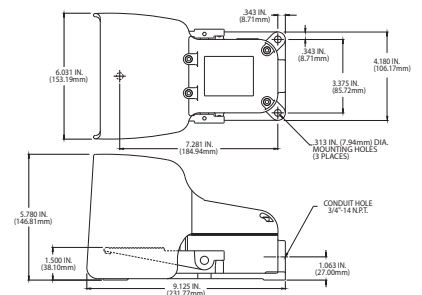

Accessories - Awareness Cover

AWARENESS COVER

CATALOG NUMBER: 522-U37 (ORANGE) AND 522-U37-1 (GRAY)

- Alerts you to the location of the foot switch
- Watch for tripping hazards
- Accepts wide range of foot switch models
- Resistant to impact
- Ergonomic design to accommodate most footwear
- Non-corrosive material
- Exceptional value and quality
- Standard color is high visibility alert orange
- Special variations available in production quantities
- Complete with non-skid feet
- Opening is large and easy to access
- Versatile and Lightweight
- Entire foot switch is covered

Size (HxWxD):	5.72 x 6.05 x 5.28 In.
Weight:	8.50 oz.

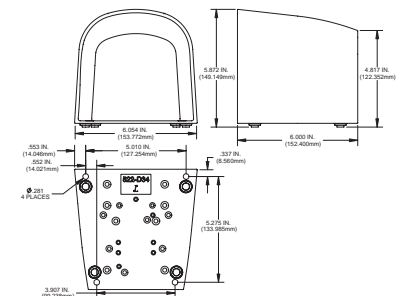

Accessories - Guards

FULL GUARD

CATALOG NUMBER: 522-B14

- Heavy gage rolled steel and welded construction
- Resistant to impact
- Opening designed to easily accommodate most footwear
- Standard color is high visibility alert orange
- Special variations available in production quantities
- Complete with non-skid feet
- Entire foot switch is covered
- Accepts wide range of foot switch models

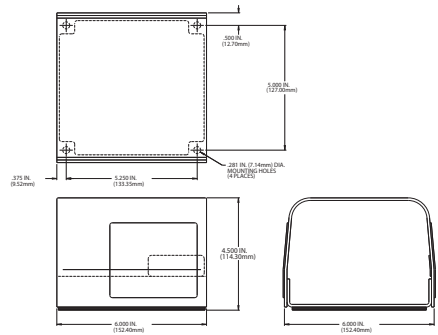

Size (HxWxD):	4.50 x 6.00 x 6.00 In.
Weight:	4.50 lbs.

FULL TWIN GUARD

CATALOG NUMBER: 522-B12

- Heavy gage rolled steel and welded construction
- Resistant to impact
- Opening designed to easily accommodate most footwear
- Standard color is high visibility alert orange
- Special variations available in production quantities
- Complete with non-skid feet
- Entire foot switch is covered
- Accepts wide range of foot switch models

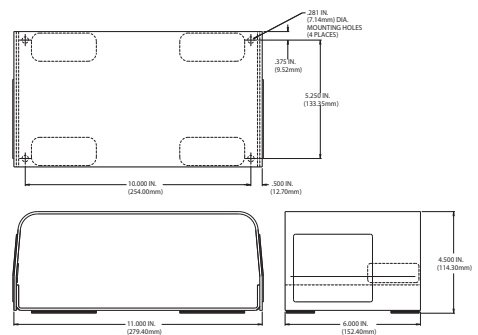

Size (HxWxD):	4.50 x 11.00 x 6.00 In.
Weight:	6.75 lbs.

SINGLE OVERSIZED GUARD

CATALOG NUMBER: 522-F28

- Heavy gage rolled steel and welded construction
- Resistant to impact
- Opening designed to easily accommodate protective footwear
- Standard color is high visibility alert orange
- Special variations available in production quantities
- Complete with non-skid feet
- Entire foot switch is covered
- Accepts wide range of foot switch models

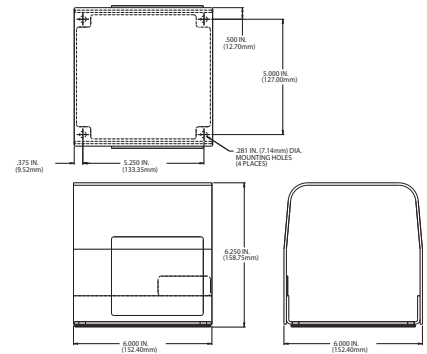

Size (HxWxD):	6.25 x 6.00 x 6.00 In.
Weight:	5.00 lbs.

OVERSIZED TWIN GUARD

CATALOG NUMBER: : 522-D28

- Heavy gage rolled steel and welded construction
- Resistant to impact
- Opening designed to easily accommodate protective footwear
- Standard color is high visibility alert orange
- Special variations available in production quantities
- Complete with non-skid feet
- Entire foot switch is covered
- Accepts wide range of foot switch models

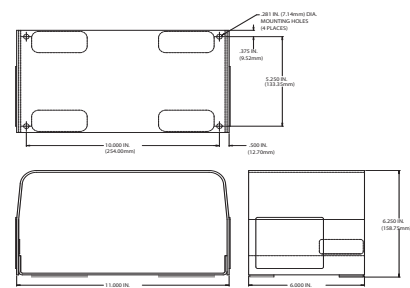

Size (HxWxD):	6.25 x 11.00 x 6.00 In.
Weight:	7.00 lbs.

Accessories - Guards

FULL GUARD STAINLESS STEEL

CATALOG NUMBER: 522 - K26

- Heavy gage Brushed Stainless Steel and welded construction
- Resistant to impact
- Opening designed to easily accommodate protective footwear
- Special variations available in production quantities
- Complete with non-skid feet
- Entire foot switch is covered
- Accepts wide range of foot switch models

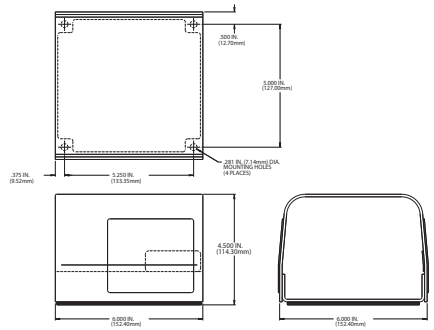

Size (HxWxD):	4.50 x 6.00 x 6.00 In.
Weight:	3.50 lbs.

MEDICAL GUARD

CATALOG NUMBER: 997-Z26

- Cast Aluminum Housing with steel base plate construction
- Resistant to impact
- Opening designed to easily accommodate protective footwear
- Special variations available in production quantities
- Complete with non-skid feet
- Entire foot switch is covered
- Accepts wide range of foot switch models

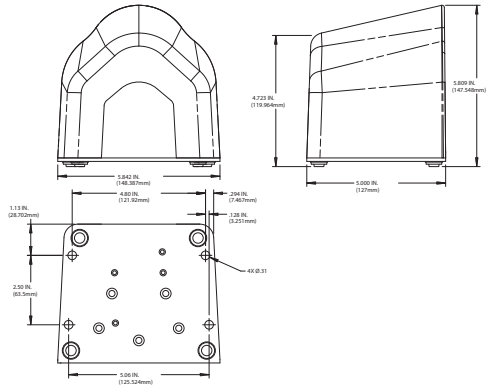

Size (HxWxD):	5.50 x 5.00 x 5.85 In.
Weight:	3.00 lbs.

Accessories - Protective Boot

PROTECTIVE BOOT

CATALOG NUMBER: 522-N30 (ORANGE) AND 522-N30-1 (BLACK)

- Plastisol PVC material in bright orange
- Easy to apply over Clipper & Clipper 88 foot switches.
- No special tools required
- Prevents materials in wet or dirty environments from entering the housing
- Not available for wide-treadle models.
- Note: Requires Modification when used with Full Guard. Please contact factory for details.

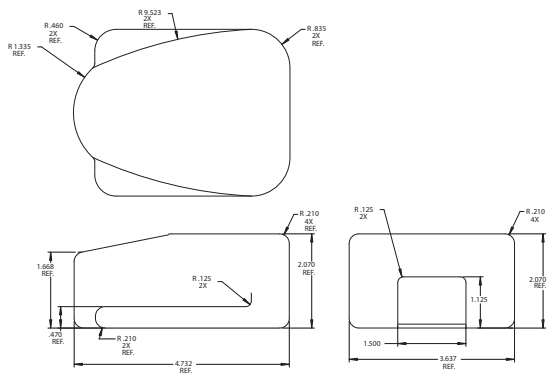

Size (HxWxD):	2.07 x 4.74 x 3.64 In.
Weight:	3.10 oz.