

Monnit

Wireless Water Rope Sensor

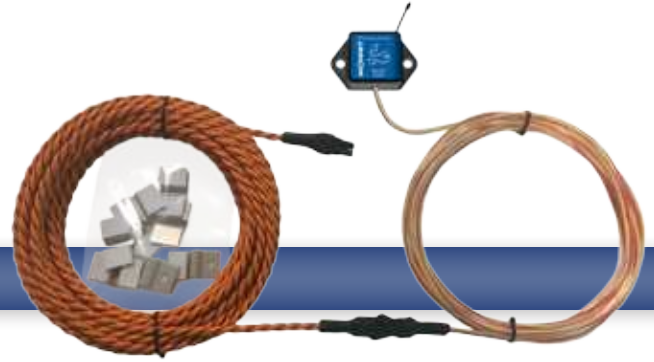

Technical Overview

General Description

The Wireless Water Rope Sensor detects the presence of water anywhere along the surface of the rope. Sensor comes with 10 feet of water rope. Additional 10 ft. sections are available and can be connected up to 100 feet.

Features

- 10 ft. lead and 10 ft. water detection rope.
- Immediately detects water anywhere along rope.
- Expandable up to 100 ft. of detection rope.
- Free iMonnit basic online wireless sensor monitoring and notification system to configure sensors, view data and set alerts via SMS text and email.

Principle of Operation

The Monnit Wireless Water Rope Sensor detects conductive liquids anywhere along the length of the detection rope by using two wires covered with conducting polymer. When water or conductive liquid contacts the rope, the sensor will immediately turn on the RF radio and transmit the data to the wireless gateway and iMonnit Online Sensor Monitoring and Notification System, allowing the user to immediately receive an alert by SMS text, email or voice call. The sensor rope dries quickly allowing the sensor to reset for next use. Detection rope can be expanded up to 100 feet by simply clicking additional 10 foot sections of detection rope together. Additional sections of water detection rope are available on the Monnit website.

Power Options

Sensors are powered by a replaceable 3.0 V coin cell battery. Optional AA battery powered sensors are available. The AA version of these sensors are larger in size (3" [L] x 2.1" [W] x 1.2" [H]) and include two long-life AA batteries.

It is recommended that unless you are using the AA battery solution, you set heartbeat to no faster than one hour to preserve battery life.

Monnit Sensor Core Specifications

- Power: Replaceable 3.0 V coin cell battery
- Communication: RF 900, 920, 868 and 433 MHz
- Dimensions: 1.775" x 1.040" x 0.785"
- Antenna: 4" wire antenna
- Operating Temperature: -7° to 60°C (20° to 140°F)
- Device Range: 250 - 300 ft. non-line-of-sight*
- Battery Life: At 1 hour heartbeat setting, coin cell battery will last ~ 1-2 years.**

* Actual range may vary depending on environment.

** Battery life is determined by sensor reporting frequency and other variables.

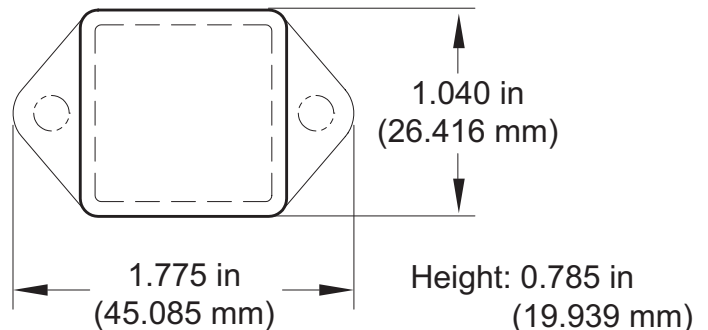

Example Applications

- Data center and server room water monitoring.
- Document retention center monitoring.
- Basement water monitoring.
- Plumbing leak detection.
- Boat bilge monitoring.
- Storage monitoring.

The Leader in Low Cost Wireless Sensors

Water Detection Rope Specifications	
Material	PE + alloy lead
Weight	30g/meter
Pull Force Limit	60kg
Fire Resistance	Second pressure plenum cable
Cable Diameter	5.5mm
Core Resistance	3ohm/100 meters
Maximum Exposed Temperature	75°C (167°F)
Cable length	10 ft. (120 in.) included (expandable to 100 ft.)
Sensor Electronics Specifications	
Supply Voltage	2.0 - 3.6 VDC *
Current Consumption	0.7 µA (sleep mode) 2 mA (radio idle/off mode) 2 mA (measurement mode) 25 mA (radio RX mode) 35 mA (radio TX mode)
Operating Temperature Range (Board Circuitry and Coin Cell)	-7°C to +60°C (20°F to +140°F)**
Optimal Battery Temperature Range (Coin Cell)	+10°C to +50°C (+50°F to +122°F)
Certifications	 900 MHz product; FCC ID: ZTL- RFSC1 and IC: 9794A-RFSC1. 920 MHz product; ARIB STD-T108 R210-103733. 868 and 433 MHz product tested and found to comply with: CISPR 22:2008-09 / EN 55022:2010 - Class B and ETSI EN 300 220-2 V2.4.1 (2012-05).

* Hardware can not withstand negative voltage. Please take care when connecting a power device.

** At temperatures above 100°C, it is possible for the board circuitry to lose programmed memory.

Caution/Notice:

This product is designed for application in an ordinary environment (normal room temperature, humidity and atmospheric pressure). Do not use this sensor under the following conditions as these factors can deteriorate the product characteristics and cause failures and burn-out.

- Corrosive gas or deoxidizing gas - chlorine gas, hydrogen sulfide gas, ammonia gas, sulfuric acid gas, nitric oxides gas, etc.).
- Volatile or flammable gas.
- Dusty conditions.
- Under low or high pressure.
- Wet or excessively humid locations.
- Places with salt water, oils chemical liquids or organic solvents.
- Where there are excessively strong vibrations.
- Other places where similar hazardous conditions exist.

Use this product within the specified temperature range. Higher temperature may cause deterioration of the characteristics or the material quality of this product.

