

Monnit

Wireless Activity Sensors



Technical Overview

General Description

Monnit wireless activity sensors can be used in a host of applications where detecting vibration (sudden movement) or counting the number of vibrations is required.

Features

- Detects vibration or sudden movement.
- Counts vibrations.
- Free iMonnit basic online wireless sensor monitoring and notification system to configure sensors, view data and set alerts via SMS text and email.

Principle of Operation

Profile 1: Activity Detection - sensor detects sudden movement or non-movement of a given device or surface, and alerts you of the change.

Profile 2: Activity Counter - sensor accumulates vibration activity, giving the user an idea of how much activity has occurred. Instead of just indicating that vibration is present, it quantifies the vibration by counting the number of vibrations detected in a user specified time period ("Aware State" time interval). When no vibrations are present, the sensor reports in on its basic heartbeat with a value of 0.

Power Options

Sensors are powered by a replaceable 3.0 V coin cell battery. Optional AA battery powered sensors are available. The AA version of these sensors are larger in size (3" [L] x 2.1" [W] x 1.2" [H]) and include two long-life AA batteries.

It is recommended that unless you are using the AA battery solution, you set heartbeat to no faster than one hour to preserve battery life.

Monnit Sensors Core Specifications

- Power: Replaceable 3.0 V coin cell battery
- Communication: RF 900, 920, 868 and 433 MHz
- Dimensions: 1.775" x 1.040" x 0.785"
- Antenna: 4" wire antenna
- Operating Temperature: -7° to 60°C (20° to 140°F)
- Device Range: 250 - 300 ft. non-line-of-sight*
- Battery Life: At 1 hour heartbeat setting, coin cell battery will last ~ 1-2 years.**

* Actual range may vary depending on environment.

** Battery life is determined by sensor reporting frequency and other variables.

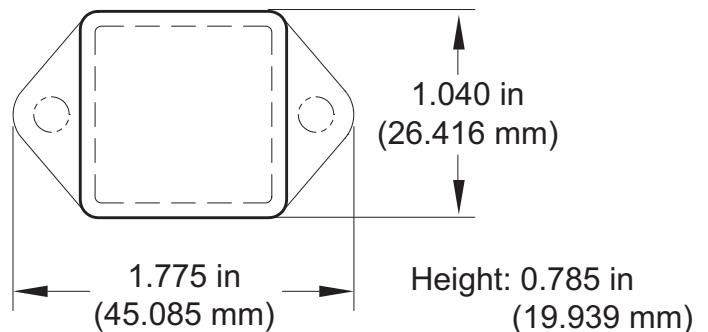

Example Applications

- Machinery monitoring.
- Pump monitoring.
- Detect if a window is broken or shattered.
- Vibration counter.

The Leader in Low Cost Wireless Sensors

Technical Specifications	
Supply Voltage	2.0 - 3.6 VDC *
Current Consumption	0.7 μ A (sleep mode) 2 mA (radio idle/off mode) 2 mA (measurement mode) 25 mA (radio RX mode) 35 mA (radio TX mode)
Operating Temperature Range (Board Circuitry and Coin Cell)	-7°C to +60°C (20°F to +140°F)**
Optimal Battery Temperature Range (Coin Cell)	+10°C to +50°C (+50°F to +122°F)
Sensitivity	0.05 g
Certifications	 900 MHz product; FCC ID: ZTL- RFSC1 and IC: 9794A-RFSC1. 920 MHz product; ARIB STD-T108 R210-103733. 868 and 433 MHz product tested and found to comply with: CISPR 22:2008-09 / EN 55022:2010 - Class B and ETSI EN 300 220-2 V2.4.1 (2012-05).

* Hardware can not withstand negative voltage. Please take care when connecting a power device.

** At temperatures above 100°C, it is possible for the board circuitry to lose programmed memory.

Caution/Notice:

This product is designed for application in an ordinary environment (normal room temperature, humidity and atmospheric pressure). Do not use this sensor under the following conditions as these factors can deteriorate the product characteristics and cause failures and burn-out.

- Corrosive gas or deoxidizing gas - chlorine gas, hydrogen sulfide gas, ammonia gas, sulfuric acid gas, nitric oxides gas, etc.).
- Volatile or flammable gas.
- Dusty conditions.
- Under low or high pressure.
- Wet or excessively humid locations.
- Places with salt water, oils chemical liquids or organic solvents.
- Where there are excessively strong vibrations.
- Other places where similar hazardous conditions exist.

Use this product within the specified temperature range. Higher temperature may cause deterioration of the characteristics or the material quality of this product.

MONNIT[®]