

Monnit Commercial

Wireless Temperature Sensor (AA)



Technical Overview

General Description

The RF Wireless Temperature Sensor uses a type NTC thermistor to measure temperature.

Features

- Accurate to $\pm 1^{\circ}\text{C}$ ($\pm 1.8^{\circ}\text{F}$)
- Increased accuracy by user calibration to $\pm 0.25^{\circ}\text{C}$ ($\pm 0.45^{\circ}\text{F}$)
- Free iMonnit basic online wireless sensor monitoring and notification system to configure sensors, view data and set alerts via SMS text and email.

Principle of Operation

The Monnit Wireless Temperature Sensor outputs the ambient temperature in degrees Fahrenheit. It is programmed to sleep for a user-given time interval (heartbeat) and then wakeup, send power to the NTC Thermistor and wait for it to stabilize, and convert the analog data, mathematically compute the temperature and transmit the data to the gateway. To stay within the abilities of the processor, the temperature is computed off a data table provided by the manufacturer. To reduce error, a variable resistor configuration is implemented over specified temperature ranges.

Power Options

The standard version of this sensor is powered by two replaceable 1.5 V AA sized batteries (included with purchase).

This sensor is also available with a line power option. The line powered version of this sensor has a barrel power connector allowing it to be powered by a standard 3.0 - 3.6 V power supply. The line powered version also uses two standard 1.5 V AA batteries as backup for un-interrupted operation in the event of line power outage.

Power options must be selected at time of purchase, as the internal hardware of the sensor must be changed to support the selected power requirements.

Monnit Sensor Core Specifications

- Power: Two replaceable 1.5 V AA batteries (Option for line power with battery backup)
- Communication: RF 900, 920, 868 and 433 MHz
- Dimensions: 4.375" x 2.470" x 1.111"
- Antenna: 4" wire antenna
- Operating Temperature: -40°C to 85°C (-40° to 185°F)
Device Range: 250 - 300 ft. non-line-of-sight*
- Battery Life: At 1 hour heartbeat setting, standard AA batteries will last up to 4 years.**

* Actual range may vary depending on environment.

** Battery life is determined by sensor reporting frequency and other variables. Other power options are also available.

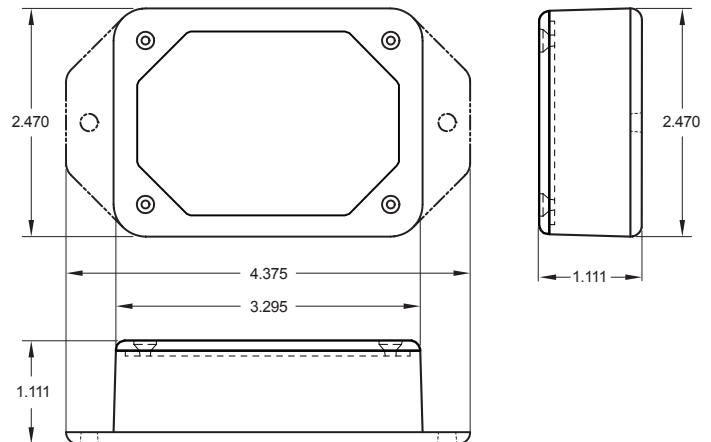

Applications

- Ambient Temperature Monitoring
- Environmental Monitoring
- Smart Machines & Smart Structures
- HVAC Operation & Testing
- Data Center Monitoring

The Leader in Low Cost Wireless Sensors

Technical Specifications	
Supply Voltage	2.0 - 3.6 VDC *
Current Consumption	0.7 μ A (sleep mode) 2 mA (radio idle/off mode) 2 mA (measurement mode) 25 mA (radio RX mode) 35 mA (radio TX mode)
Operating Temperature Range (Board Circuitry and Batteries)	-18°C to 55°C (0°F to 130°F) using alkaline -40°C to 85°C (-40°F to 185°F) using lithium **
Optimal Battery Temperature Range (AA)	+10°C to +50°C (+50°F to +122°F)
Thermistor Temperature Range (Thermistor Only)	-40°C to +125°C (-40°F to +257°F) (Limited to Main Unit Circuitry, -7°C to +60°C unless thermistor leads are being used.
Accuracy @ 25°C	+/- 1% (1° C or 1.8° F)
User Calibrated Accuracy	+/- 0.25° C (\pm 0.45° F)
Time Constant @ 25°C	15 sec max
Certifications	 900 MHz product; FCC ID: ZTL- RFSC1 and IC: 9794A-RFSC1. 920 MHz product; ARIB STD-T108 R210-103733. 868 and 433 MHz product tested and found to comply with: CISPR 22:2008-09 / EN 55022:2010 - Class B and ETSI EN 300 220-2 V2.4.1 (2012-05).

* Hardware cannot withstand negative voltage. Please take care when connecting a power device.

** At temperatures above 100°C, it is possible for the board circuitry to lose programmed memory.

Caution/Notice:

This product is designed for application in an ordinary environment (normal room temperature, humidity and atmospheric pressure). Do not use this sensor under the following conditions as these factors can deteriorate the product characteristics and cause failures and burn-out.

- Corrosive gas or deoxidizing gas - chlorine gas, hydrogen sulfide gas, ammonia gas, sulfuric acid gas, nitric oxides gas, etc.).
- Volatile or flammable gas.
- Dusty conditions.
- Under low or high pressure.
- Wet or excessively humid locations.
- Places with salt water, oils chemical liquids or organic solvents.
- Where there are excessively strong vibrations.
- Other places where similar hazardous conditions exist.

Use this product within the specified temperature range. Higher temperature may cause deterioration of the characteristics or the material quality of this product.

MONNIT®