

Monnit

Wireless Carbon Monoxide (CO) Sensor (AA)



Technical Overview

General Description

The Wireless Carbon Monoxide (CO) sensor allows you to monitor the level of carbon monoxide (CO) gas in the surrounding air.

Monnit wireless CO sensors have a small footprint and low cost but boast industry standard setting, premium performance specifications and are the longest lifetime sensors in the industry (powered by a coin cell battery and last over a year at 1 hour heartbeat).

Features

- Measures CO levels in surrounding air.
- Free iMonnit basic online wireless sensor monitoring and notification system to configure sensors, view data and set alerts via SMS text and email.

Principle of Operation

The Wireless Carbon Monoxide (CO) Sensor measures the amount of CO gas in the surrounding air. The sensor returns carbon monoxide level and temperature values to the iMonnit Online Sensor Monitoring and Notification System. The system stores both data points in the online system where the data can be reviewed and exported as a data sheet or graph. Notifications can be set up through the online system to alert the user when defined CO levels have been met or exceeded.

Power Options

The standard version of this sensor is powered by two replaceable 1.5 V AA sized batteries (included with purchase).

This sensor is also available with a line power option. The line powered version of this sensor has a barrel power connector allowing it to be powered by a standard 3.0 - 3.6 V power supply. The line powered version also uses two standard 1.5 V AA batteries as backup for uninterrupted operation in the event of line power outage.

Power options must be selected at time of purchase, as the internal hardware of the sensor must be changed to support the selected power requirements.

Monnit Sensor Core Specifications

- Power: Two replaceable 1.5 V AA batteries (Option for line power with battery backup)
- Communication: RF 900, 920, 868 and 433 MHz
- Dimensions: 4.375" x 2.470" x 1.111"
- Antenna: 4" wire antenna
- Operating Temperature: -40° to 85°C (-40° to 185°F)
Device Range: 250 - 300 ft. non-line-of-sight*
- Battery Life: At 1 hour heartbeat setting, standard AA batteries will last up to 4 years.**

* Actual range may vary depending on environment.

** Battery life is determined by sensor reporting frequency and other variables. Other power options are also available.

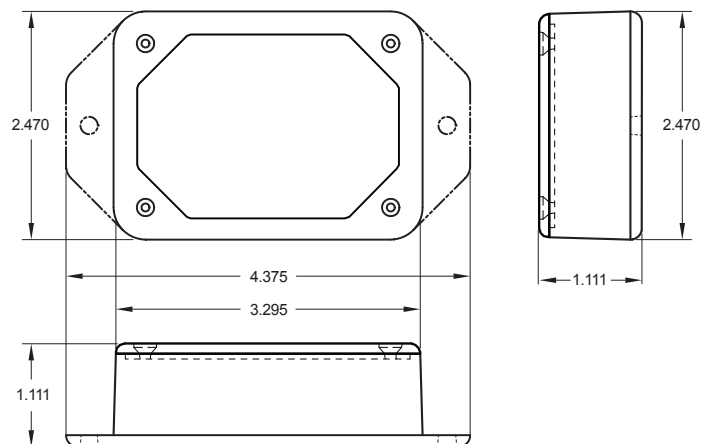

Example Applications

Monitor flame-fueled devices such as;

- Gas ranges and ovens
- Gas clothes dryers
- Furnaces
- Fireplaces
- Grills
- Space heaters
- Vehicles
- Water heaters

The Leader in Low Cost Wireless Sensors

Technical Specifications	
Supply Voltage	2.0 - 3.6 VDC (3.0 - 3.6 VDC Using Power Supply) *
Current Consumption	0.7 μ A (sleep mode) 2 mA (radio idle/off mode) 2 mA (measurement mode) 25 mA (radio RX mode) 35 mA (radio TX mode)
Operating Temperature Range (Board Circuitry and Batteries)	-18°C to 55°C (0°F to 130°F) using alkaline -40°C to 85°C (-40°F to 185°F) using lithium **
Optimal Battery Temperature Range (AA)	+10°C to +50°C (+50°F to +122°F)
Operating Pressure Range	\pm 0.2 atm (recommended)
Operating Humidity Range	15 to 85% RH
Measuring Range	0-500 PPM
Maximum Overload	1500 PPM
Measuring Principle	Electrochemical Oxidation of CO
Resolution	\pm 0.5 PPM
Response Time (t-90)	< 30 seconds typical at 20°C
Stabilization Time	< 30 seconds
Long Term Drift – Zero	Zero Signal \leq \pm 2 PPM / month
Long Term Drift – Span	Output Signal \leq \pm 2% of reading per month
Maximum Zero Shift	< 8 ppm equivalent (-20°C to +40°C)
Certifications	 900 MHz product; FCC ID: ZTL- RFSC1 and IC: 9794A- RFSC1. 920 MHz product; ARIB STD-T108 R210- 103733. 868 and 433 MHz product tested and found to comply with: CISPR 22:2008-09 / EN 55022:2010 - Class B and ETSI EN 300 220-2 V2.4.1 (2012-05).

* Hardware cannot withstand negative voltage. Please take care when powering device.

** At temperatures above 100°C, it is possible for the board circuitry to lose programmed memory.

Caution/Notice:

This product is designed for application in an ordinary environment (normal room temperature, humidity and atmospheric pressure). Do not use this sensor under the following conditions as these factors can deteriorate the product characteristics and cause failures and burn-out.; corrosive gas or deoxidizing gas - chlorine gas, hydrogen sulfide gas, ammonia gas, sulfuric acid gas, nitric oxides gas, etc.), volatile or flammable gas, dusty conditions, under low or high pressure, wet or excessively humid locations, places with salt water, oils chemical liquids or organic solvents, where there are excessively strong vibrations, other places where similar hazardous conditions exist.

Use this product within the specified temperature range. Higher temperature may cause deterioration of the characteristics or the material quality of this product.

MONNIT[®]